

# Crystal Ball Kit Lift Station Monitoring

Quick Start Guide to Empower  
Facilities Monitoring & Analyzing



Scan Here for  
Virtual Manual



# Crystal Ball Kit

## Comprehensive User Guide

### Welcome To OmniSite!

#### *The Future of SCADA*

OmniSite cares about the environment. There are tens of thousands of OmniSite monitors across the USA monitoring critical pump stations, giving you early warning, so you can prevent environmental spills.

OmniSite is fast and easy to use. **OmniSite is “the new way to do SCADA”**. Do our products report sensor data by the millisecond? NO. However, we offer instant alarm notifications, and analog values can be reported at 5 or 15 minute intervals based on the report package you selected. This solution is definitely “quick enough” to keep you “in the clean” and saves you a lot of time and money.

Don't be fooled by old school SCADA providers who sell tremendously expensive, slow, complex solutions. Look at the below picture, and honestly ask yourself “Do we have anyone on staff who can work on that?” If your answer is “no” then OmniSite is for you!



Using cellular airwaves and the Internet, OmniSite delivers services using a refined solution. This saves you money and time in the long run. The solution is also straightforward, allowing your multi-tasking personnel to seamlessly alternate between mundane tasks and utilizing OmniSite's services. OmniSite can be used without prior expertise in telemetry, programming, and controls, allowing you to focus on what matters most to you: operating your facility.

OmniSite is a cloud-based solution, so there is no software to buy or install. Our software platform, called GuardDog, includes iPhone and Android apps at no additional cost. Any phone, tablet, or PC that can browse the web can use GuardDog. Receive flexible notifications via email, text, or voice call using our easy configuration system. Have extensive history on your pumps and equipment without creating laborious SCADA graphic screens. OmniSite does all this out-of-the-box.

# Attention Installer!!

It is mandatory that you connect **ALL THE WIRES, PUMP AMP PROBES, AND WELL LEVEL TRANSMITTER** as described on the following pages!!

This Crystal Ball cellular and cloud based monitor/analyzer/controller is ALMOST LIKE MAGIC, but it's definitely not 100% magic

This device cannot deliver ANY of the following advanced reports, if YOU don't connect the needed wires as shown on the following pages

## Why Proper Installation Matters

Cutting corners during installation—especially by skipping steps outlined in this manual—can result in your customer not receiving the full functionality they were promised, including important reports highlighted in both the product literature and sales process. When expectations aren't met, customers lose trust and often choose not to work with you again.

## Why Do Omnisite Monitors Sometimes Get Improperly Wired?

Improper wiring is often the result of underestimating the time needed for correct installation, configuration, testing, and customer training. Taking shortcuts may seem time-efficient in the moment, but it can lead to major issues down the line—ones that impact both the installer's credibility and customer satisfaction.

To ensure a successful experience for everyone, **it's essential to connect, at minimum, the wires and devices specified in this manual.** Additional inputs are available to support even more features, should your customer require them. Taking the time to do it right the first time will pay off in long-term reliability and customer loyalty.

## INCLUDED REPORTS

- Pump 1 amp history
- Pump 1 cycles history
- Pump 1 runtime history
- Pump 1 GPM history
- Pump 1 on/off status history
- Pump 1 failure history
- Pump 2 amp history
- Pump 2 cycles history
- Pump 2 runtime history
- Pump 2 GPM history
- Pump 2 on/off status history
- Pump 2 failure history
- Pump 3 amp history
- Pump 3 cycles history
- Pump 3 runtime history
- Pump 3 GPM history
- Pump 3 on/off status history
- Pump 3 failure history
- Total station daily flow history
- Well inflow rate history & level
- Rainfall history
- Daily Radar Rainflow
- User Audit Trail history
- Notification History
- Alarm History
- Email, Text, Voice Notifications

## ADVANCED REPORTS

- Database Backups
- Cybersecurity Protection
- 24/7 Tech Support
- Warranty
- Time/Day call plan scheduler
- Volumetric Flow Calculations
- Counters
- Pump Control
- Local Display Interface
- Smart Access Key

# Crystal Ball Kit

## Comprehensive User Guide

### **NOTICE**

INSPECT CONTENTS IMMEDIATELY  
AND FILE CLAIM WITH DELIVERING  
CARRIER FOR ANY DAMAGE

### **SAVE THE BOX AND PACKING MATERIAL**

YOU ARE RESPONSIBLE FOR DAMAGE TO YOUR  
UNIT IF RETURNED IMPROPERLY PACKED

**WARNING:** The individual user should take care to determine prior to use whether this device is suitable, adequate or safe for the use intended. Since individual applications are subject to great variation, the manufacturer makes no representation or warranty as to suitability or fitness of these devices for any specific application.

## General Safety Instructions

### Safety Signal Words

**Danger:** means if the safety information is not followed, someone will be seriously injured or killed.

**Warning:** means if the safety information is not followed, someone could be seriously injured or killed.

**Caution:** means if the safety information is not followed, someone may be seriously injured or killed.

**1. To reduce the risk of fire or shock hazard, connect OmniSite RTU directly to a 120 VAC electrical circuit. Do not use extension cords for permanent installation.**

**2. Cover of OmniSite RTU must be securely closed to prevent water damage and electrical shock.**

**3. Never operate your OmniSite RTU while any part is missing or damaged in any manner.**

**4. To reduce the risk of electrical hazard or damage, do not tilt, jolt or tip RTU while unit is powered-on.**

**5. To reduce the risk of accidental electrical shock, do not touch the electrical terminals or controls with wet hands.**

**6. Note the warning label shown below.**

**WARNING: To reduce risk of fire, electric shock, or injuries always disconnect all sources of electrical power before servicing or cleaning.**

## INTRODUCTION

Congratulations - you just bought the best. The OmniSite system provides two-way communications using our patented WINGS™ (Wireless IOT Network Gateway Server) over a cellular network. The low cost of the OmniSite method makes remote monitoring very affordable and allows our devices to operate on cellular networks across the USA. We have the most complete coverage and best reputation in the industry.

OmniSite wireless monitoring devices provide a low-cost wireless system for remote monitoring, measurement, and data collection anywhere wherever there is cellular service.

### Overview

The OmniSite Crystal Ball is a multi-channel monitoring and control device that has been optimized for use by the water and wastewater utilities. It is designed for indoor or outdoor environments, and operates from 120VAC or +15-20 VDC solar panels and power supplies. The product's internal cellular radio provides two-way communications through the fully automated OmniSite cloud platform, GuardDog. ([www.guarddog.omnisite.com](http://www.guarddog.omnisite.com))

The standard operating program of the RTU monitors all (14) digital inputs and the alarm limits on (4) analog inputs and reports any changes. This information is immediately displayed on the web site, and user selectable alarm notifications for critical events can be sent via text, e-mail, telephone call or any combination thereof. Equipment status reports can be scheduled in advance or requested at any time. In addition, the Crystal Ball is a sophisticated pump controller.

## Installation and Operation is Very Simple:

**Please note that your OmniSite product is a cellular device.** No matter how good the installation looks, without cellular reception, your device will not work!

Therefore, your first step is to determine whether suitable cellular service is available at the installation location BEFORE you start your actual installation. Connect your OmniSite unit to a temporary extension cord, and plug it in at the installation location.

Look at the cellular signal strength LED on the Crystal Ball. If it is GREEN, you have a good signal and can proceed with installation. If NOT GREEN, call OmniSite at 317-885-6330 to determine that your cellular signal strength is suitable. Once this is verified you can move-on to installing your equipment with confidence.

**Observe good wiring practices** - DO NOT MIX high and low voltage wiring inside your pump control panel. This creates a situation where high voltage cables can "induce" false signals onto your low voltage OmniSite inputs.

OmniSite low voltage cables should be routed inside low voltage wiring duct in your existing control panels. If you are not sure if high & low voltages are mixed inside your panel, you can always "tie-wrap" your OmniSite sensor wires to the outside of the wiring duct. This technique still provides an attractive installation while providing suitable separation from high voltages.

**CAUTION** - If you mount your OmniSite RTU inside of your existing electrical cabinet, then take extra care to **ensure that the antenna coaxial cable is NOT routed with high voltage cables or alarm horn power wires.** This can lead to unpredictable cellular reception or damage to the radio circuitry.

### **OmniSite RTU's can be mounted indoors or outdoors**

OmniSite's cellular devices can be mounted directly outdoors (if you purchased the NEMA 4X polycarbonate enclosure option), or inside of your existing electrical control panel if room allows. A common installation technique is to mount the RTU inside the existing electric control panel you are monitoring; mount our "Phantom" antenna on top of your existing panel; then connect the antenna to the RTU using an OmniSite supplied coax jumper cable. Note that your antenna must be mounted outside of any metal electrical enclosure.

# Crystal Ball Kit

## Comprehensive User Guide

### Table of Contents

Technical Support .....	07
Technical Specifications .....	08
Components .....	10
1.0 Activation .....	11
2.0 Mounting .....	17
3.0 Wiring .....	20
4.0 Configure Internal Settings .....	28
5.0 GuardDog Website Setup .....	34
5.1 Create Callout List .....	35
5.2 Create Callout Plan .....	37
5.3 Device Setup Page .....	39
Advanced Features .....	46
Peer to Peer Control Instructions .....	55
Reports .....	66
6.0 Troubleshooting .....	74
Using Crystal Ball as a Pump Controller .....	87
Reference .....	98
Freebies .....	106
Product Safety, Use and Limited Warranty .....	114

Available In  
Virtual Manual

Scan Here for  
Virtual Manual



# Crystal Ball Kit

## Comprehensive User Guide

### TECHNICAL SUPPORT

---

Have questions or comments about your Crystal Ball Kit? Please contact:



203 W. Morris Street  
Indianapolis, IN 46225  
support@OmniSite.com  
**317-885-6330 x3**

FREE WORLD-CLASS SUPPORT!  
[www.OmniSite.com](http://www.OmniSite.com)

# Crystal Ball Kit

## Comprehensive User Guide

### TECHNICAL SPECIFICATIONS

---

#### OmniSite Crystal Ball

I/O:	Accepts (14) Universal Digital Inputs- any voltage in the range of+ 12VDC or VAC to+ 120VDC or VAC. Opto-isolated 4000 VAC isolation   (4) 20A form C relay outputs   (4) 4-20mA analog inputs. Analog input-1 includes 4000V opto-isolation   (3) Pulse Inputs: 0-30hz from dry contact or open collector device (1 pulse input reserved for 0.01" pulsing rain gauge)
Input Power:	80-260 VAC @ 0.5A max or optional 15 VDC @2A max
Terminal Blocks:	Gray color, removable style, spring-clamp accepts #14-22 AWG solid or stranded wire
External Power Source:	12 VDC@ 100mA battery backed internal power source available for powering external un-powered alarm contacts, and non-battery-backed for powering 4-20mA loop powered devices.
SD Memory Card Slot:	On-board SD memory card slot for data logging and software updates
Battery Backup:	Internal 12 VDC, rechargeable 800mA/hr sealed lead acid battery rated for 4 hours backup during AC power loss
Operating Temperature:	-20 - 150 °F
Operating Humidity:	0-90% RH, non-condensing
Cellular Radio:	4G/LTE CAT-1
Antenna:	Multiband LTE Antenna, optional remote mount high gain antennas and cables available
Display:	4 line X 20 Char white background LCD w/ backlight. Includes "easy-use" navigation buttons
Personal ID Key Reader:	Smart key reader to identify maintenance personnel. (1) smart key included
Enclosure:	Standard unit is hinged painted steel design w/ remote mount keypad suitable for direct panel mount. Optional NEMA 4X polycarbonate enclosure w/ stainless locking hasps and solid or clear cover available. Larger Enclosure will also be available.
Dimensions:	panel mount - 8.5"W x 8.2"H x 3.5"D - with optional NEMA 4X enclosure - 12"H x 10"W x 4" D
Weight:	Weight: Standard panel mount - 7.0 lbs , with NEMA 4X enclosure - 7.5 lbs.
Protection:	Protection: US Patent #7,228,129

# Crystal Ball Kit

## Comprehensive User Guide

### TECHNICAL SPECIFICATIONS CONTINUED

---

#### Submersible Level Transducer

Measurement Range:	0-20 ft.
Accuracy:	0.5%/0.2% F.S (including linearity, repeatability, and hysteresis)
Long Term Stability:	± 0.2 % F.S. per year
Output Signal:	4mA to 20 mA (two-wire type)
Power Supply:	12 VDC - 24 VDC ± 10%
Response Time:	10ms
Allowed Overpressure	2.5 times full scale
Compensated Temperature:	from -10°C to +60°C
Load Impedance:	50K $\Omega$ min. for < 0.1% FSO attenuation
Input Current:	8mA nominal
Insulation Resistance:	10M $\Omega$ @ 50 VDC and +70 degrees F
Connection:	60 ft of 3-conductor #20g Hytrel jacketed Cable with breather tube utilizing Teflon hydrophobic filter. Optional 100ft can be purchased.
Weight:	5 lbs.
Materials:	All 316 stainless steel exterior body and diaphragm
Operating Temperature:	32 Degrees F - 150 Degrees F
Thermal Drift:	+/- 2.0% FS 50/100 Degrees F

#### Amp Probes

Model :	MI-420MAP
Amperage Rating:	0-100, 0-150, 0-200 Amps, user selectable jumper
Sensor Output:	4 to 20 mA Accuracy +/-0.5% FS
Supply Voltage:	12-40 VDC Loop Powered
Isolation:	1270 VAC

# Crystal Ball Kit

## Comprehensive User Guide

### Included Components:

- (1) Crystal Ball in NEMA 4X Enclosure with (4) 3/4" sealite connectors
- (1) 10' Digital Input Cable 600VAC
- (2) 10' Analog Input Cable 600VAC
- (1) 10' 18/3 Power Cable 600VAC
- (2) 4-20mA Amp Probe
- Optional Additional Amp Probe Available
- (1) 0-20' Submersible Level Transducer or radar sensor
- (2) Pre-landed terminal block sets for digital and analog input
- (1) Pre-landed terminal for power
- 8 ft of 3/4" sealite plastic conduit
- (1) Accessory bag

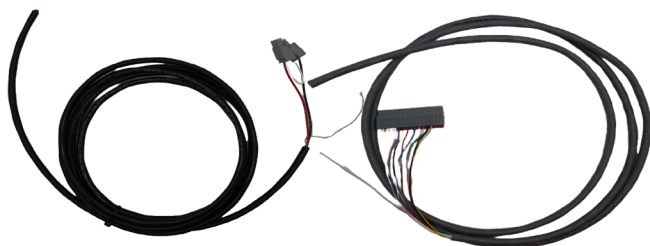
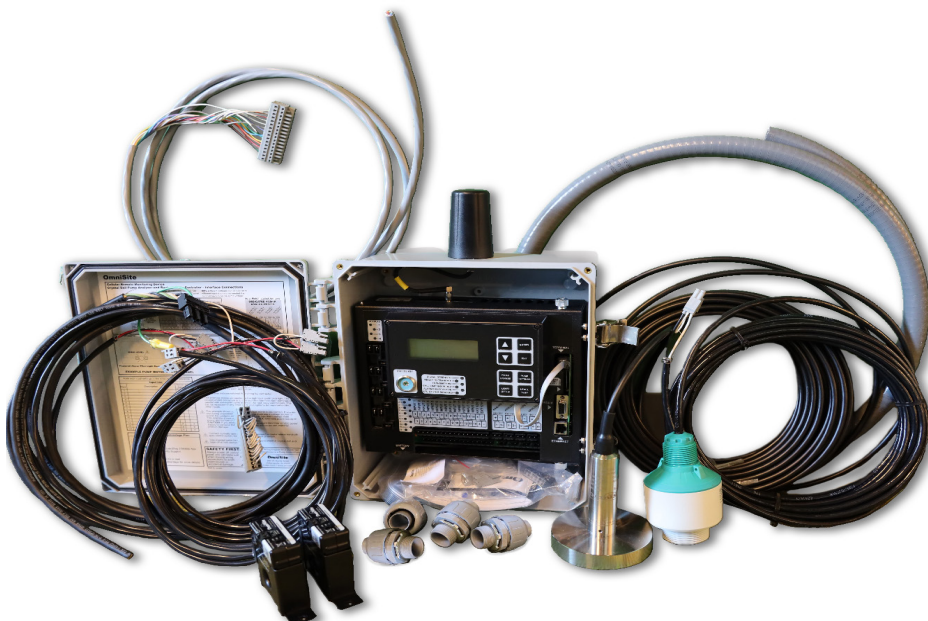

Digital and Analog input cables



Amp Probe



sealite plastic conduit



sealite connectors



Pre-landed terminal for power



Accessory bag



Radar Sensor

OR



Submersible Level Transducer

---

# ACTIVATION STEP #1

---

# Crystal Ball Kit

## Comprehensive User Guide

### STEP #1

#### 1.0 ACTIVATION

The Crystal Ball is a cellular device just like your cell phone. As such, all OmniSite devices require activation before it will transmit alarms.

Note: Activation should be done before installation, login also requires Primary User GuardDog credentials

Please follow the instructions below to activate your device.

- 1.1. Navigate to [www.OmniSite.com/activate](http://www.OmniSite.com/activate) to launch the Activation Wizard or Scan the QR code below.

Scan Here

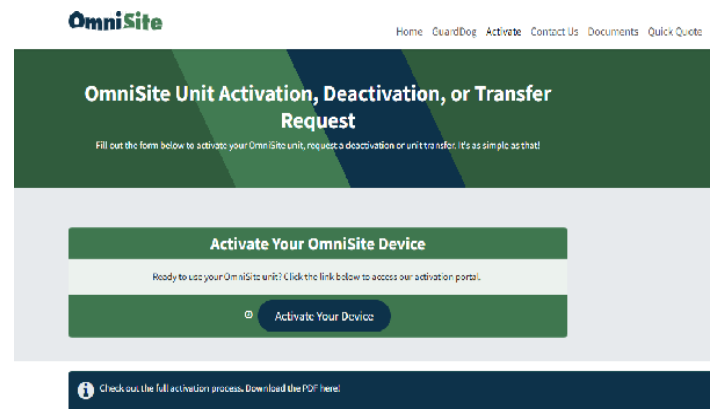

- 1.2. Select an appropriate account type

- If you are a new customer, select "New Customer" to create a new account
- If you are an existing customer, select "Existing Customer" to log into your account. Select activation and skip to 1.6.
- If you are an OmniSite representative, select "OmniSite Representative" to log into your account

How do I find my Unit Number?

Use this form to Activate wireless service for your OmniSite units. To begin, please select if you are a New Customer (you have never owned an OmniSite product), an Existing Customer (you already have a GuardDog account), or an OmniSite Representative (you wish to activate a unit for your customer) Once the correct option is selected, please press the 'Next' button.

- Account Type -

New Customer  
 Existing Customer (Login to your account)  
 OmniSite Representative (Authorized Resellers or Master Reps)

Next

\*Required Field

# Crystal Ball Kit

## Comprehensive User Guide

**1.3.** All wireless billing is billed annually. You can choose the billing frequency for pre-paying for one, two, or three years. (The longer terms cost less per year)

Please enter your customer information for your new account.  
You may select One Year, Two Years, or Three Years for billing frequency.  
You will be able to select a payment method in a future step and you will receive an invoice for continuation of service when your billing cycle is about to end.

- New Customer -

Become an OmniAdvantage Customer

[Click for more Information on the OmniAdvantage Plan](#)

\*Customer Name:

\*TimeZone:

\*Phone: ( ) - - -

Alternate Phone Number: ( ) - - -

\*Billing Frequency:

Previous

Next

**1.4.** Billing Contact: This area is for **customer contact** information only. If representative is filling out activation for customer, do not enter representative name.

Please enter the Primary Contact and Billing Contact for new account.  
If you are a representative filling out this activation form, we MUST have the customer's address information for the activation to be completed.

- Contacts -

<p align="center">- Primary Contact -</p> <p>*First Name: <input type="text"/></p> <p>*Last Name: <input type="text"/></p> <p>Email: <input type="text"/></p>	<p align="center">- Billing Contact -</p> <p>*First Name: <input type="text"/></p> <p>*Last Name: <input type="text"/></p> <p>Email: <input type="text"/></p>
---	---

✔ Use the Same Contact Information

Previous

Next

Check Box: Check here if Primary Contact and Billing Contact are the same

Note: If customer information is not provided, this can put their account at risk when the billing period ends.

**1.5.** Address: Addresses should be customer Main Address & Shipping Address. Do not enter rep contact info, even if rep is paying for first year of service.

Please enter your Billing and Shipping information for your new account.  
Representatives: DO NOT enter your address here, we MUST have the customer's address for the activation to be completed.  
Please double check this information below, as your invoice will be mailed to the information in the billing address fields.

- Addresses -

<p align="center">- Billing Address -</p> <p>*Address: <input type="text"/></p> <p>*City: <input type="text"/></p> <p>*State: <input type="text"/></p> <p>*Zip: <input type="text"/></p>	<p align="center">- Shipping Address -</p> <p>*Address: <input type="text"/></p> <p>*City: <input type="text"/></p> <p>*State: <input type="text"/></p> <p>*Zip: <input type="text"/></p>
--	---

✔ Use the Same Address Information

Previous

Next

Check Box: Check here if Main Address & Shipping Address are the same.

# Crystal Ball Kit

## Comprehensive User Guide

- 1.6. Multiple Units:** Multiple units can be activated at the same time.

Please press the 'Add Unit' button to begin adding your units for activation. During this process, you must select your wireless service plan: Standard, Elite and OmniBeacon plans are for units that report to GuardDog.

- Units to Activate -

+ Add Unit

Edit	Device	Wireless Service	Purchase Order Number	Reactivation
Press the 'Add Unit' button above to add devices to your request.				
<i>0 Devices will be activated</i>				

Previous
Next

- 1.7. UNIT ID:** Locate your unit's ID number and insert here. (The sticker is located on top of the Crystal Ball's painted black metalwork.)

**CELL SERVICE:**

**Elite Service:** Device submits a selected report every 15 minutes, plus a daily report summary and immediate alarm notifications.

**Real time:** Real Time Alarms, Real Time Pump Data, Peer to Peer Pump Control Capability, and Realtime Reporting. Analog inputs reported every 5 minutes maximum

**PO:** Place your purchase order number for service here. If you pre purchased wireless service this box will autopopulate

Unit Activation - Settings

Unit ID:\*

Wireless Service:

Purchase Order Number:

Wireless Service Comparison  
 Warranty Information

Save Cancel

Note: If a cellular PO/Key was not purchased along with your unit you may enter "Verbal, <Customer name>".

- 1.8. Activation:** Activations can take up to one full business day after submission. We suggest activating units 1-2 days before installation.

**Deactivation:** Billing for a unit will continue until the unit is deactivated. All deactivated units are subject to a \$100 fee upon reactivation.

> How do I find my Unit Number?

- Activation Notice -

Once a Device has been activated your account will be billed for the wireless service and package selected. Although activation is generally very quick during standard business hours, M-F 8am-5pm EST, activation can require up to one business day. You will be given the option to be notified upon successful activation later in this wizard. Please note that if a unit has been previously deactivated, there is a \$100 reactivation fee per device. You will be given a chance to review all costs as well as change your billing options before your request is submitted.

Previous
Next

\*Required Field

# Crystal Ball Kit

## Comprehensive User Guide

**1.9.** Username: Can be any length and be numeric or alphabetic.

Password: Must be a minimum of 5 characters, 1 special character and 1 number

Voice Pin: Must be 6 digits. Many customers use the first 6 digits of their phone number

(This Step Is For New Customers Only)

[> How do I find my Unit Number?](#)

Please enter all of the information below to set up your GuardDog account. The 'Six Digit VoicePin' will be used when you call 888-947-1212 to hear status, or acknowledge alarms when calling from any phone.

- Primary Login -

The information entered below is used to set up the Administrative(Primary) account you will use to log on to GuardDog (the online private unit management, reporting website)

\*Username: emmiepence

\*Password: ●●●●●  
(Minimum 5 Characters)

\*Confirm Password: ●●●●●

\*Account Email: epence@omnisite.com

\*Six digit VoicePin: 985911

Previous Next

\*Required Field

**1.10.** Fees: All recurring subscription fees associated with the activation are noted here. You will be invoiced for the correct amount once submitted. IF you are reactivating a unit you will see it under the one time fee box.

[> How do I find my Unit Number?](#)

- Fee Summary -

Additions to Annual Bill			
Description	Quantity	Amount	
Standard 1 Year Wireless Service Plan	1		See Below*
			<b>\$0.00</b>

\*If paying with a PO you will be billed for the service selected.

One Time Fees			
Description	Rate	Quantity	Amount
No One Time Fees Apply			

Previous Next

\*Required Field

**1.11.** Email: This is how we will notify you once the activation is complete.

Comments/Notes: Note any special circumstances regarding this activation here. (e.g. Unit is replacing another unit that is being deactivated.)

[> How do I find my Unit Number?](#)

Please enter a valid Email address below. OmniSite will use this address to notify you when your units are activated. If you do not want to be notified add 'Do not notify' in the comments.

- Confirmation Options -

\*Email: epence@omnisite.com

Comments/Notes:

Previous Next

\*Required Field

# Crystal Ball Kit

## Comprehensive User Guide

**1.12.** Check box: Check this after reading and agreeing to the Service Plan Agreement Terms.

Submit Button: Once you have verified that all information is correct and checked the box, click the submit button.

[> How do I find my Unit Number?](#)

Please make sure that the information below is correct. You may correct any errors by using the 'Previous' button and editing your selections. Once this information is submitted you will be billed for the wireless service selected. If you fail to pay for your wireless service upon receipt of the invoice, OmniSite will promptly disconnect your wireless service.

- Final Confirmation -

**Device(s) to be Activated:**

Device	Wireless Service	Purchase Order Number
41571	Standard 1 Year Wireless Service	

**Wireless Plan Fee:**  
**One Time Fee:**  
**Notification:** epence@omniste.com  
**Comments:**

[Click to read Service Plan Agreement Terms](#)

I have read and accept the terms of the Service Plan Agreement

**If the above information is correct, press the Submit button below.**

Previous Submit

\*Required Field

### Success!

Your unit(s) should be activated within one business day. Any changes to information noted in this activation wizard should be communicated to the OmniSite technical support team immediately to ensure accurate service and billing.

---

# MANDATORY MOUNTING STEP #2

---

# Attention Installer!!

It is mandatory that you connect **ALL THE WIRES, PUMP AMP PROBES, AND WELL LEVEL TRANSMITTER** as described on the following pages!!

This Crystal Ball cellular and cloud based monitor/analyzer/controller is ALMOST LIKE MAGIC, but it's definitely not 100% magic

This device cannot deliver ANY of the following advanced reports, if YOU don't connect the needed wires as shown on the following pages

**WHAT HAPPENS WHEN YOU TRY TO SAVE MONEY ON YOUR INSTALLATION TIME AND NOT WIRE AS SHOWN IN THIS MANUAL?** - Your customer will not get the reports they were promised in the product literature, plus promised by the salesman who sold this device. When your customer does not get what they paid for, they become unhappy, and in the future, they are no longer your customer! Cutting corners simply creates your next ex-customer!

## **WHY OMNISITE MONITORS DON'T GET WIRED PROPERLY?**

It's because the salesperson or the service installer Estimates far too little time to correctly install, setup, and test their product. You also need to give your customer training. Don't make this mistake, plus don't cut corners and try to save installation time. This will haunt YOU LATER! **Do the right thing AND CONNECT AT AN ABSOLUTE MINIMUM THE WIRES AND DEVICES SHOWN IN THIS MANUAL.** There are many spare inputs to connect more.

## INCLUDED REPORTS

- Pump 1 amp history
- Pump 1 cycles history
- Pump 1 runtime history
- Pump 1 GPM history
- Pump 1 on/off status history
- Pump 1 failure history
- Pump 2 amp history
- Pump 2 cycles history
- Pump 2 runtime history
- Pump 2 GPM history
- Pump 2 on/off status history
- Pump 2 failure history
- Pump 3 amp history
- Pump 3 cycles history
- Pump 3 runtime history
- Pump 3 GPM history
- Pump 3 on/off status history
- Pump 3 failure history
- Total station daily flow history
- Well inflow rate history & level
- Rainfall history
- Daily Radar Rainflow
- User Audit Trail history
- Notification History
- Alarm History
- Email, Text, Voice Notifications

## ADVANCED REPORTS

- Database Backups
- Cybersecurity Protection
- 24/7 Tech Support
- Warranty
- Time/Day call plan scheduler
- Volumetric Flow Calculations
- Counters
- Pump Control
- Local Display Interface
- Smart Access Key

# Crystal Ball Kit

## Comprehensive User Guide

### STEP #2

#### 2.0 MOUNTING & WIRING YOUR CRYSTAL BALL KIT- STEP 2

---

OmniSite's cellular devices can be mounted directly outdoors (if you purchased the NEMA 4X polycarbonate enclosure option), or inside of your existing electrical control panel if room allows. A common installation technique is to mount the RTU inside the existing electric control panel you are monitoring; mount our "Phantom" antenna on top of your existing panel; then connect the antenna to the RTU using an OmniSite supplied coax jumper cable. Note that your antenna must be mounted outside of any metal electrical enclosure.

**CAUTION** - If you mount your OmniSite RTU inside of your existing electrical cabinet, then take extra care to ensure that the antenna coaxial cable is NOT routed with high voltage cables or alarm horn power wires. This can lead to unpredictable cellular reception or damage to the radio circuitry.

---

# **MANDATORY WIRING STEP #3**

---

# Crystal Ball Kit

## Comprehensive User Guide

### STEP# 3

### 3.0 WIRING

All the wires are already connected to the Crystal Ball field terminal blocks. Please see the wiring legend below for the bottom terminal. The top has been pre-wired with the white jumper and one white wire that connects to the neutral.

### Digital Inputs

INPUT NUMBER	DESCRIPTION	WIRE COLOR
Input 1	High Wet Well Level	Black Wire (Mandatory connection)
Input 2	Pump 1 Overload	Brown Wire (Optional connection)
Input 3	Pump 2 Overload	Orange Wire (Optional connection)
Input 4	Phase Failure	Yellow Wire (optional, may not be in all panels)
Input 5	Low Wet Well Level	Green Wire (Optional connection)
Input 6	Spare Input	Blue Wire
Input 7	Spare Input	Purple Wire
Input 8	Pump 1 Seal Failure	Gray Wire (optional, may not be in all panels)
Input 9	Pump 2 Seal Failure	White Wire (optional, may not be in all panels)
Input 10	Tamper Switch	White/Black Wire (optional, may not be in all panels)
Input 11	Spare	White/Brown Wire

NOTE: Do not mix AC and DC return wiring, this will cause erroneous operation or damaged inputs, potentially voiding the warranty. Keep specific voltage returns separated!

Any signal 12 VAC/VDC to 120 VAC/VDC. No polarity required. Typical for all digital inputs.

NOTE: Different voltages can be applied to different input channels as needed (i.e. don't all have to be the same)

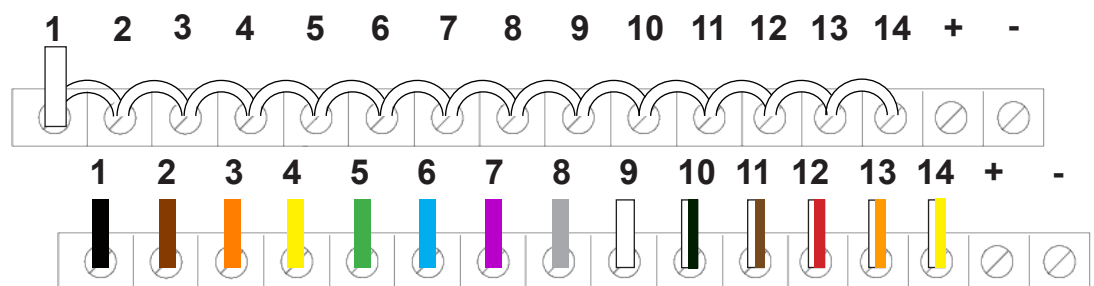

# Crystal Ball Kit

## Comprehensive User Guide

### Runtime Inputs

INPUT NUMBER	DESCRIPTION	WIRE COLOR	
Input 12	Pump 1 Runtime	White/Red Wire	(Mandatory Connection)
Input 13	Pump 2 Runtime	White/Orange Wire	(Mandatory Connection)
Input 14	Pump 3 Runtime	White/Yellow Wire	(Mandatory Connection)

(The extra red wire in the cable is used when wiring a 12VDC signal. See virtual manual for more details.)

### Analog Inputs

INPUT NUMBER	DESCRIPTION	WIRE NUMBER*	
Input 1*	I-Level (Well Level)	Analog Wire 1**	(Mandatory Connection)
Input 2	Pump 1 Amps	Analog Wire 2	(Mandatory Connection)
Input 3	Pump 2 Amps	Analog Wire 3	(Mandatory Connection)
Input 4	Spare	Analog Wire 4	(Optional Connection)

\*NOTE: We've pre-connected an Analog black/red wire pair to all three analog inputs as shown below.

\*\* Analog Input 1 is not pre-wired since it receives the rigid cable from the Submersible Level Transducer or Radar Sensor. This will be shown later in this manual.

\*\*\* Crystal Ball Analog Input Impedance = 250 ohms

\*\*\*\* 12VDC @ 80 mA max, each input

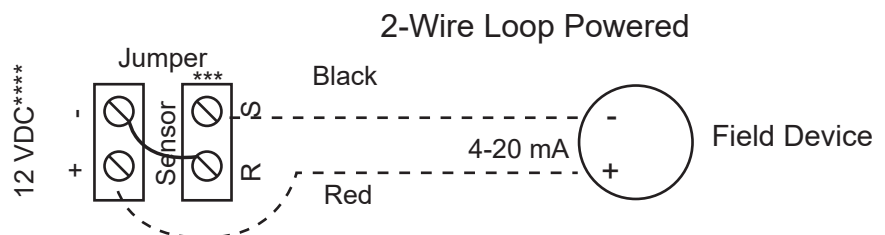

# Crystal Ball Kit

## Comprehensive User Guide

### Wiring Diagram

Use the following images to wire up the

- High Wet Well Level,
- Pump 1 & 2 Overload,
- Pump 1-3 Runtimes,
- The I-Level (Submersible Well Level Transducer),
- Pump 1 & 2 Amps Probes in your panel.

**Fig. 1: Complete Wiring Diagram**

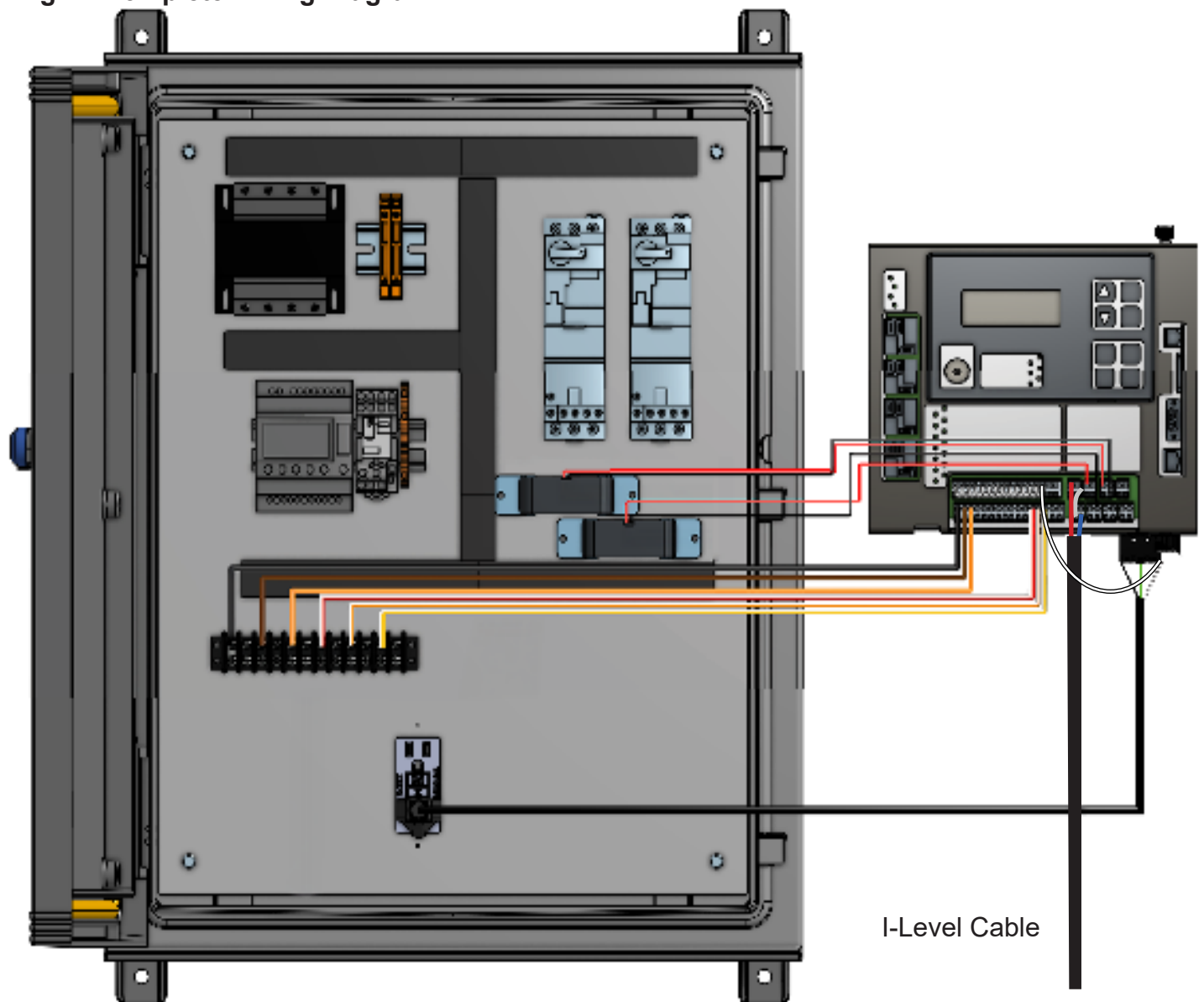

# Crystal Ball Kit

## Comprehensive User Guide

**Fig. 2: Wiring High Wet Well Level**

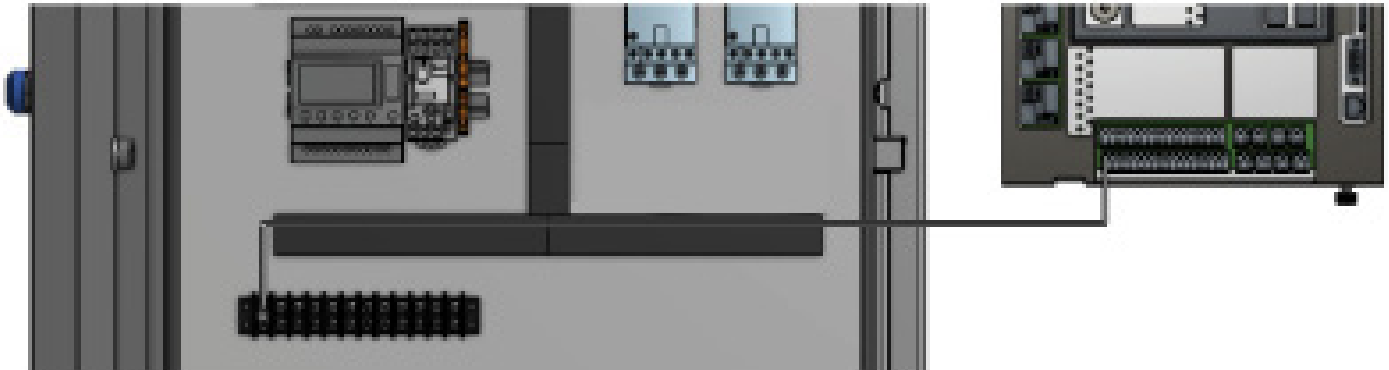

Wire Input 1 on the Crystal Ball to the terminal strip in the electrical box using the black wire. This wire should land on the “switched side” of the high-level float such that 120 V power is supplied to the Crystal Ball when the high float tilts up, indicating high level alarm.

**Fig. 3: Wiring Pump 1 Overload**

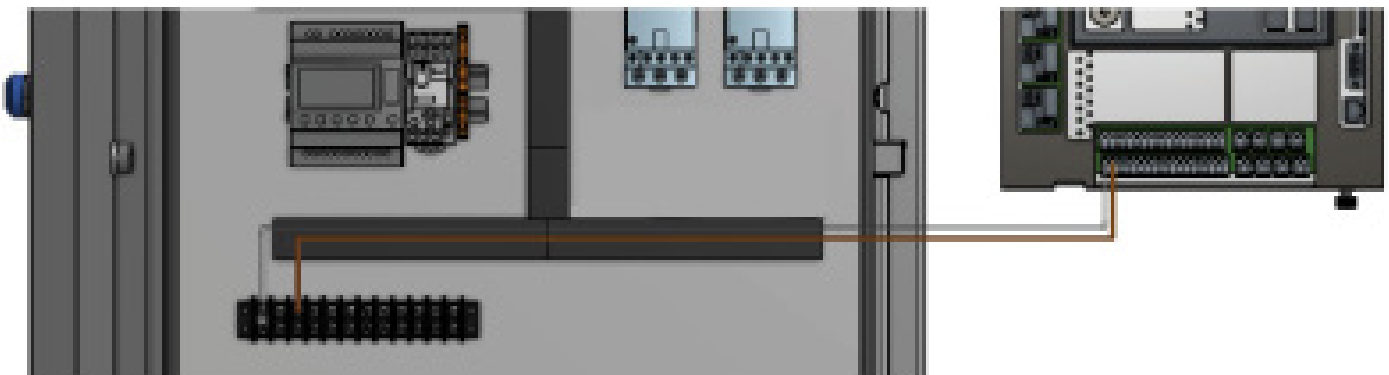

Wire Input 2 on the Crystal Ball to the terminal strip in the electrical box using the brown wire. This wire should land on the “hot side” of the overload contacts such that when the overload trips, voltage is applied to the Crystal Ball. When overload is not tripped, voltage is NOT supplied to Crystal Ball.

**Fig. 4: Wiring Pump 2 Overload**

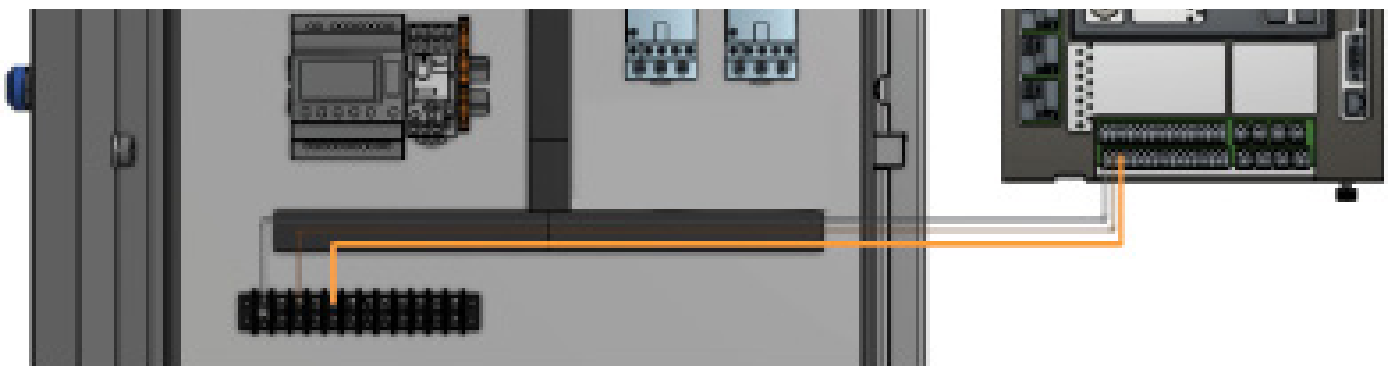

Wire Input 3 on the Crystal Ball to the terminal strip in the electrical box using the orange wire. Wire pump #2 overload identically to pump #1 overload (as shown in Fig. 3.)

# Crystal Ball Kit

## Comprehensive User Guide

**Fig. 5: Pump 1 Runtime**



Wire Input 12 on the Crystal Ball to the terminal strip in the electrical box using the white/red wire. This wire should land on hot side of the motor starter coil, or run light, such that voltage is applied to Crystal Ball when motor starter is energized.

**Fig. 6: Pump 2 Runtime**

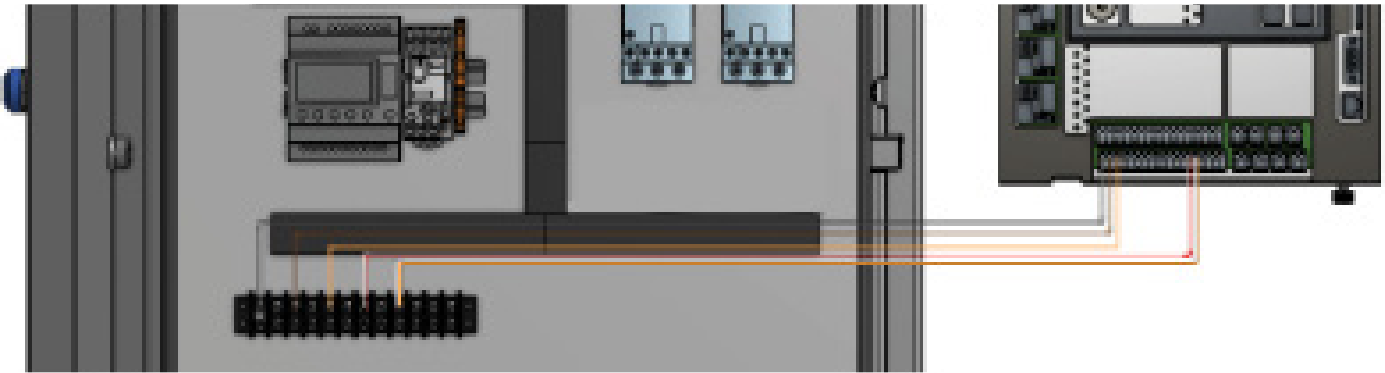

Wire Input 13 on the Crystal Ball to the terminal strip in the electrical box using the white/orange wire. Wire identically to Pump 1 runtime (as shown in Fig. 5)



Wire Input 14 on the Crystal Ball to the terminal strip in the electrical box using the white/yellow wire. Wire identically to Pump 1 runtime if Pump 3 exists (as shown in Fig. 5)

# Crystal Ball Kit

## Comprehensive User Guide

**Fig. 8: Terminal Strip for Digital Inputs Neutral Wire**



Find the terminal block with 13 white jumpers from input 1-14. Plug this terminal block into the top terminal block spot. Make sure there is a 8 inch white jumper wire from terminal 14 to the neutral on the power plug. ( These wiring steps are for 120 VAC signals. For wiring up 12 VDC signals see virtual manual.)

**Fig. 9: I-Level Transducer- Well Level Readings**

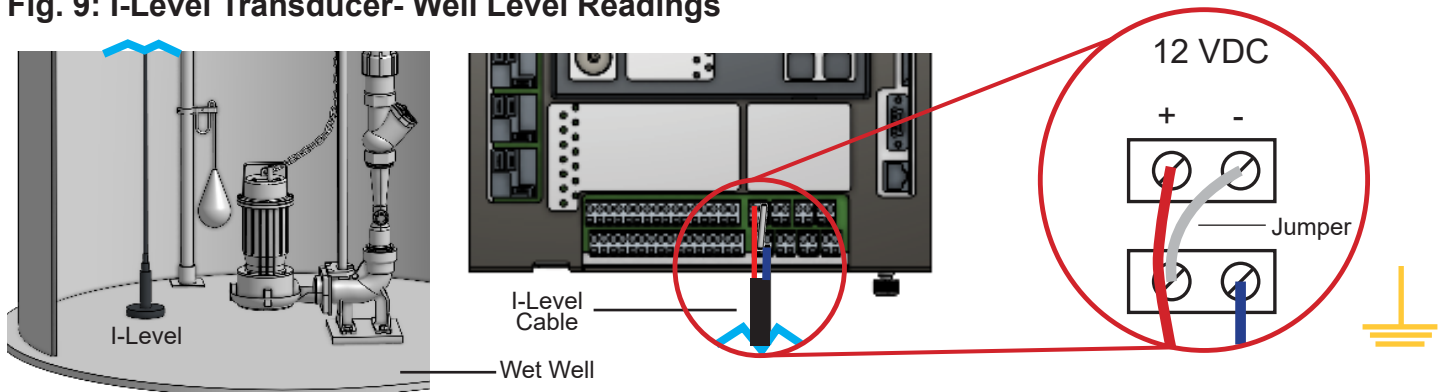

Place I-Level on floor of wet well. Wire Analog 1 to the I-Level as indicated by the red and blue wires. Connect the yellow wire to ground. If you purchased the radar kit see virtual manual.

**Fig. 10: Install Amp Probes**

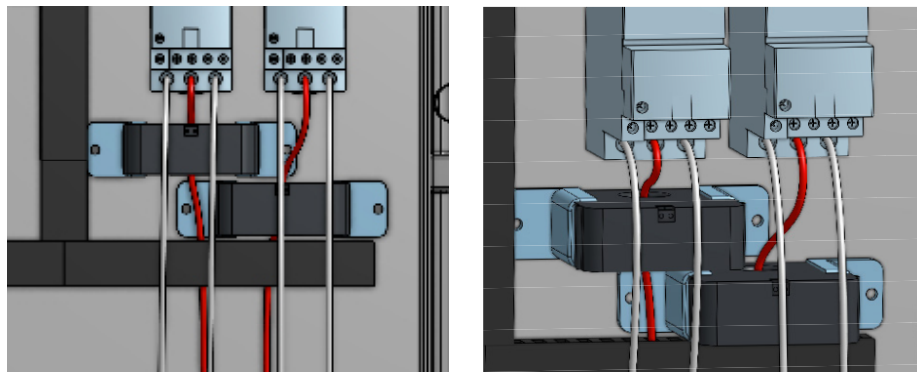

**NOTE:** When installing the signal wires from the Crystal Ball to the amp probe, avoid routing the signal wires too close to the pump power wires, as this may create false signals or alarms.

Install both amp probes by mounting them in the control panel beneath the motor starters. Pass one of the hot leads from one of the starters through the center of one of the amp probes, passing the other two wires around the outside of the probe. Repeat this process with the second starter and amp probe. Make sure the selector switch on the amp probe is set to the appropriate setting (50 or 100 amps) for your application. If monitoring variable speed drives, the amp probes must be mounted on the LINE SIDE of the variable speed drive.

# Crystal Ball Kit

## Comprehensive User Guide

**Fig. 11: Amp Probe 1 Wiring**

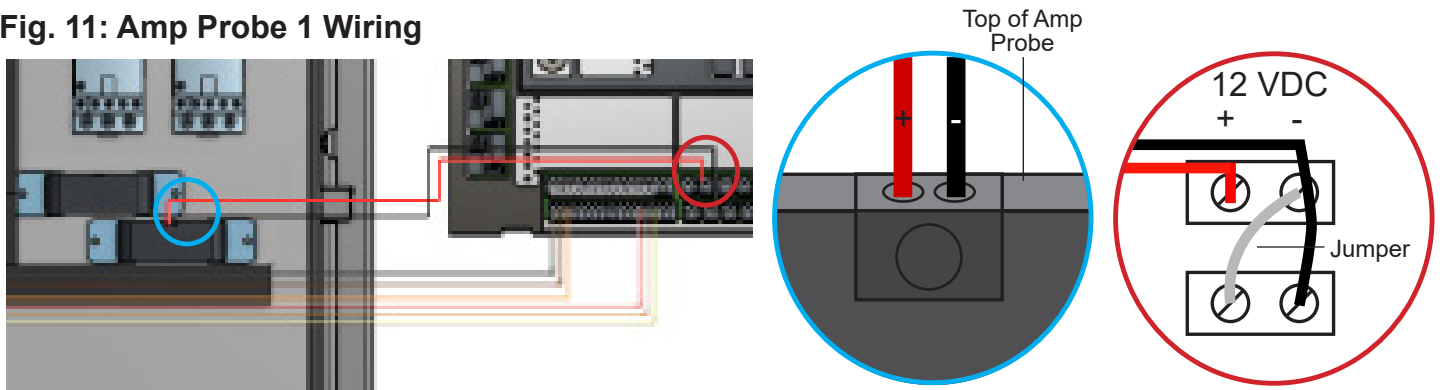

Wire Analog 2 to Amp Probe 1 for Pump 1 as indicated by red and black wire. Make sure to connect the shield wire to ground at the Crystal Ball, and tape off the shield at the amp probe.

**Fig. 12 Amp Probe 2 & Wiring**

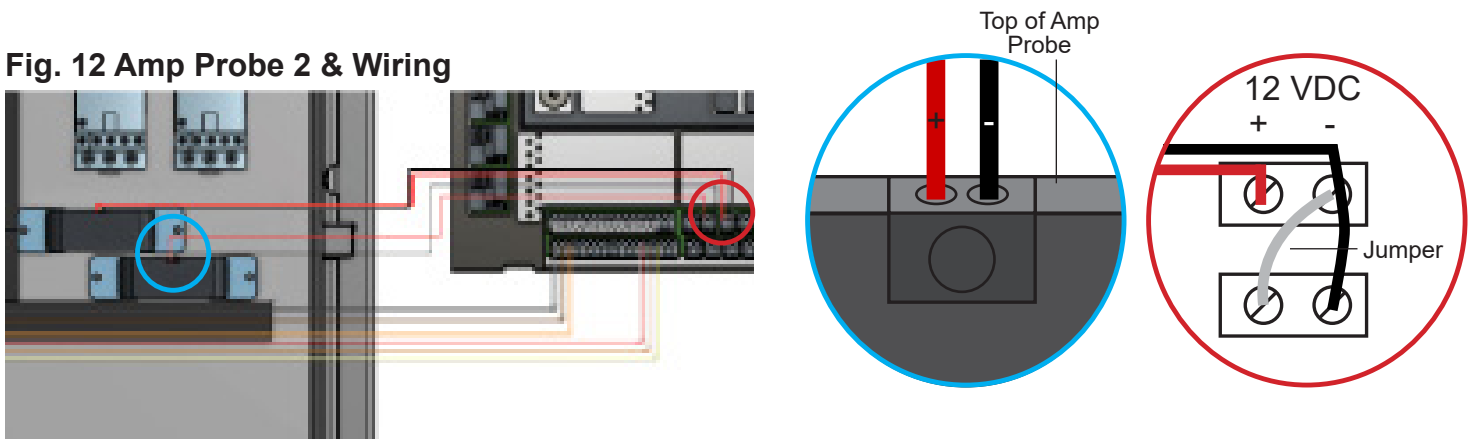

Wire Analog 3 to Amp Probe 2 for Pump 2 as indicated by red and black wire. Make sure to connect the shield wire to ground at the Crystal Ball, and tape off the shield at the amp probe.

**Fig. 13 Power**

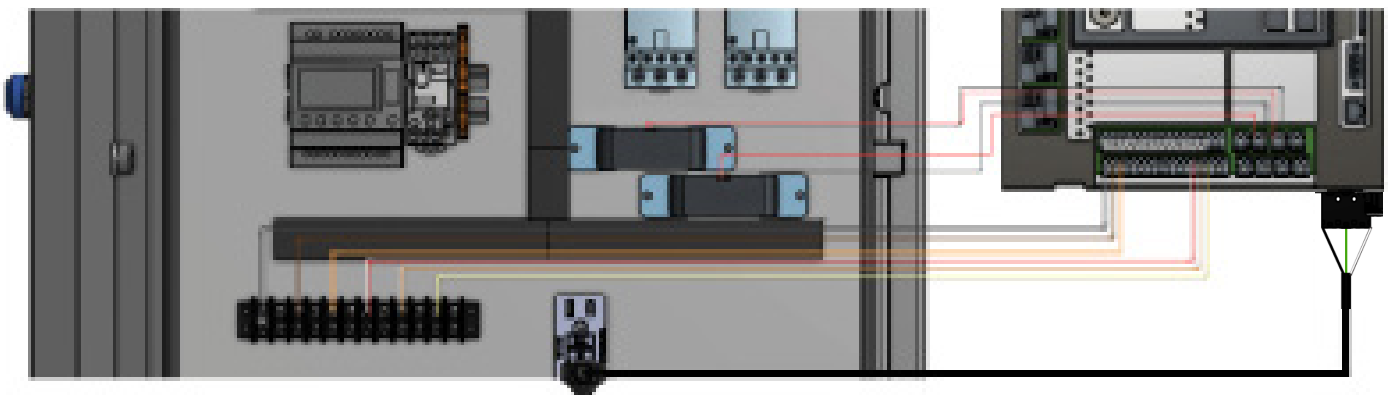

Connect the power supply to the bottom of the Crystal Ball to the outlet in the electrical panel. You can also “hard wire” your H,N,G conductors as desired.

**NOTE:** This diagram shows how to wire up the basic functions. If you want to add the other options, use the wiring diagram in the full online manual.

---

# **CONFIGURE INTERNAL SETTINGS MANDATORY STEP #4**

---

# Crystal Ball Kit

## Comprehensive User Guide

### STEP #4

## 4.0 PROGRAMMING THE CRYSTAL BALL MENU TREE- MANDATORY

### Programming Alarm Delays

#### 4.1 Main Menu - hit ENTER

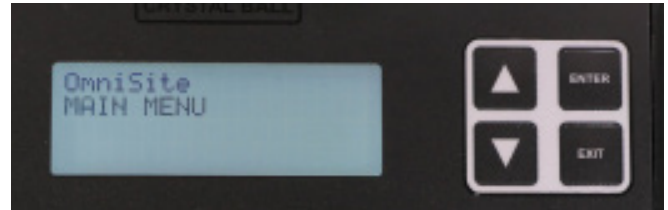

#### 4.2 Enter Setup - Scroll down using the arrow keys until ENTER SETUP is blinking. Press ENTER.

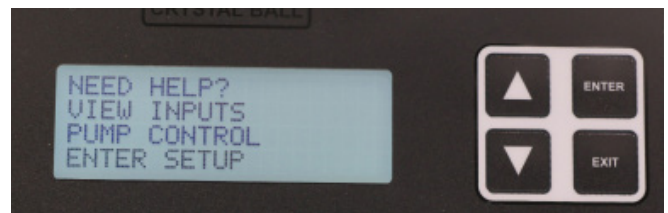

#### 4.3 IMPORTANT STEP- Scroll down using the arrow keys until SETUP DIGITAL INPUTS is blinking. Press ENTER.

*At this step you can set the alarm time delay desired for each of your digital inputs. Factory default is 5 seconds on all digital inputs, and 60 seconds for system power failure. Be sure to set delays that don't cause false momentary alarms. To change a time delay, scroll to the input desired using arrow keys. It will start blinking. Press ENTER to change delay. Delay number will start blinking. The number shown is in seconds. Use UP/DOWN arrow keys to adjust any time delays. When set, press ENTER to save. Repeat for any other digital inputs.*

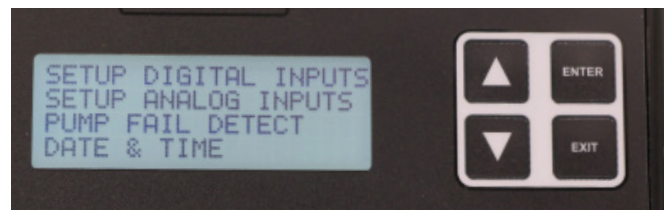

(To change settings the unit will have to be disabled. To disable the product use the black key in the accessory bag.)

# Crystal Ball Kit

## Comprehensive User Guide

### Programming Pump GPM Calculations- Mandatory Step

**4.4** Scroll down using the arrow keys until PUMP GPM CALCS is blinking. Press ENTER.



**4.4.1** Set Max GPM for each pump monitored. Press ENTER and adjust with arrow keys.  
**NOTE:** This value should be greater than what the pump is rated for, usually between 1.5 and 2 times the rating.



**4.4.2** Select the shape of your wet well  
**OPTIONS:** Cylinder, Rectangle

**4.4.3** Select a decimal position that makes sense for your application.  
**OPTIONS:** XXXX, XXX.X, XX.XX, X.XXX

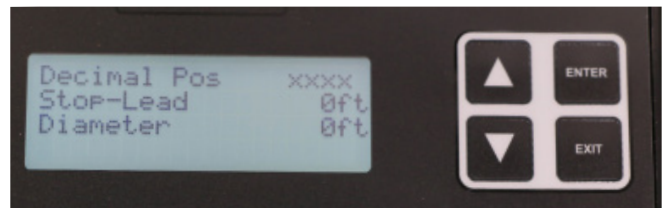

**4.4.4** Set Stop-Lead to the distance between start and stop points for your pumps.

**4.4.5** Set the diameter (if Cylinder) or width and length (if Rectangle) of your wet well.

**NOTE:** Both values are in feet for Cylindrical and Rectangular wet wells.

# Crystal Ball Kit

## Comprehensive User Guide

### Programming Analog Inputs- Mandatory Step

**4.5** Main Menu - Press ENTER



**4.6** Enter Setup - Scroll down using the arrow keys until ENTER SETUP is blinking. Press ENTER.

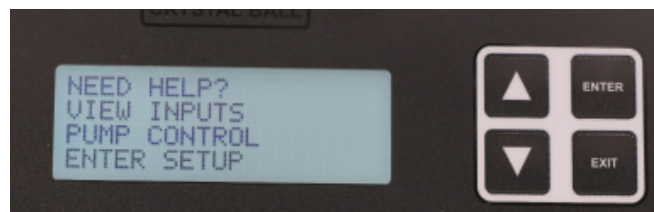

**4.7** Scroll down using the arrow keys until SETUP ANALOG INPUTS is blinking. Press ENTER.

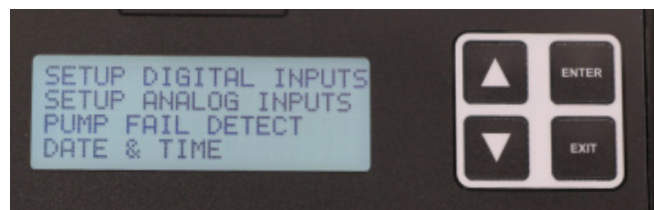

**4.8** Setup Analog Input 1 -

ANALOG INPUT 1 should be blinking. Press ENTER.



# Crystal Ball Kit

## Comprehensive User Guide

**4.9** Using the arrow keys and ENTER button, make the following changes:

Decimal Position: XX.XX

4mA Setting: 0.00\*

20mA Setting: 20.00\*

Low Alarm: NONE

*\*These values should be configured based on the scaling of your device. Since the I-Level transducer we are using is designed for a range of 0-20 feet, we set the scaling accordingly*

High Alarm: Set in feet (0-20ft) where high alarm should trip.

Deadband: This is how much water level must lower to return to normal (in feet).

Alarm Delay: Set where you won't get false alarms. *Default is 5 seconds, meaning high level must be exceeded for 5 seconds before the Crystal Ball will send a notification.*

Output 4 Ctrl: NO

Press EXIT when finished.

**4.10** Setup Analog Inputs 2 -

ANALOG INPUT 2 should be blinking. Press ENTER.

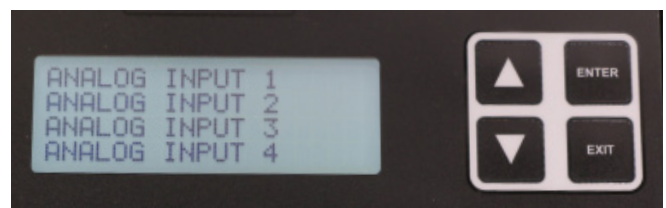
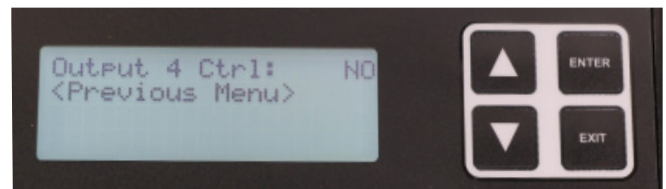
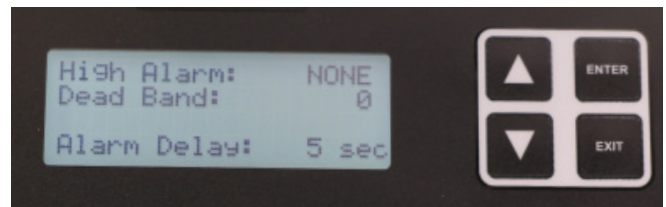
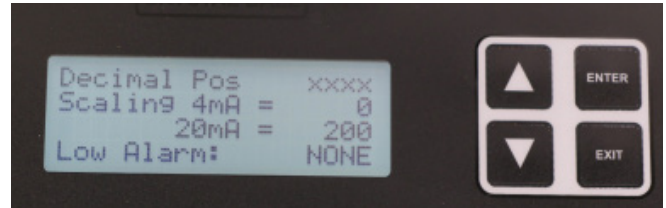

# Crystal Ball Kit

## Comprehensive User Guide

**4.11** Using the arrow keys and ENTER button, make the following changes for Input 2:

Decimal Position: XX.XX

4mA Setting: 0.00\*

20mA Setting: 50 or 100 amps\*

Low Alarm: NONE

*\*Since the amp probe we are using is adjustable, you should set the scaling to match the setting on the amp probe.*

High Alarm: NONE

Deadband: 0.0

Alarm Delay: 5 s

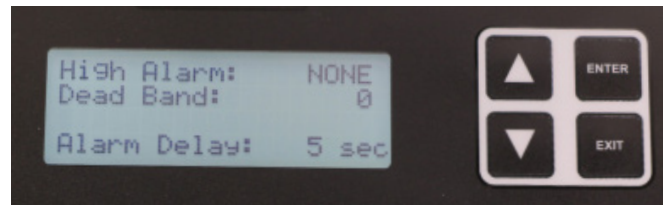
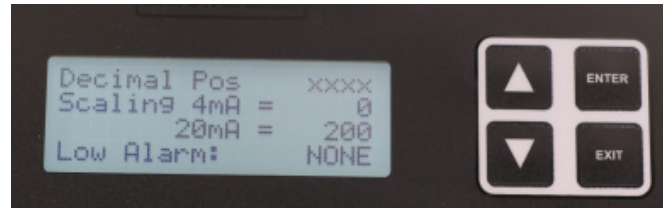

**4.12** After Alarm Delay has been set, use the arrow keys to scroll down to REPORT VALUE. Verify it is set to LAST.

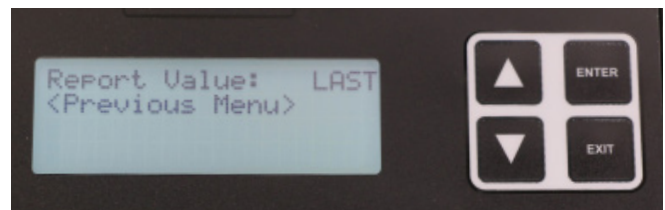

**4.13** Repeat for Analog 3 and 4 (if present)

**4.14** Verify the steps in the checklist below have been completed. Make sure the unit is enabled.

### IMPORTANT!

- FINAL CHECKLIST:**  Unit enabled?  Entered GPM info?  Entered time delays?  Signal strength good/green?  
 Test inputs?  Verify unit transmitted?  Battery plugged in?

---

# **MANDATORY WEBSITE SET-UP STEP #5**

---

# Crystal Ball Kit

## Comprehensive User Guide

### STEP#5

## 5.0 GUARDDOG WEBSITE SETUP

GuardDog is used to view device status, see current alarms, configure devices, and setup notifications.

GuardDog must be configured to send notifications and alarms regarding your OmniSite devices.

There are four main steps required to configure GuardDog:

- (1) Add Recipients to Recipient Library
- (2) Create Callout List
- (3) Create Callout Plan
- (4) Configure Alarms

### 5.1 Add Recipients to Recipient Library

**5.1.1.** Navigate to <https://guarddog.OmniSite.com/login> and enter your username and password to log in. If you are a new customer, your username and password will be provided when activation of your device is complete.

*If you are unsure how to proceed on this step, contact Tech Support at (317) 885-6330 X 3.*



**5.1.2.** Using the navigation icons on the left side of the screen, hover over the gear icon and select "Callout System".

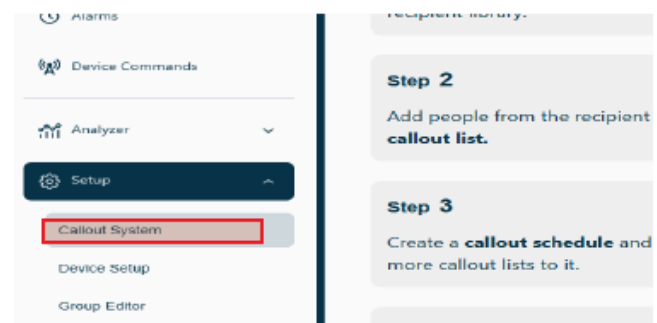

**5.1.3.** This is the main page for your callout system. Follow these steps to create your cohesive callout system. Click on the recipient library "more details" button to begin the steps.

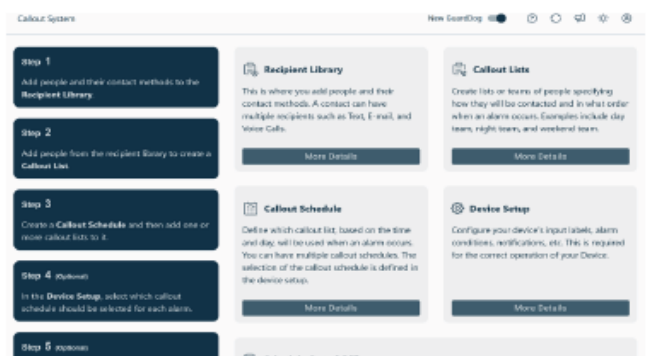

# Crystal Ball Kit

## Comprehensive User Guide

**5.1.4.** Add new recipients with the ADD CONTACT button at the top. Your list must have at least two of the three required methods of notification; Phone call, Text, or Email. You may have multiple entries for a single individual.

Or add new details to existing recipients by clicking the Add recipient to the left of their existing info.

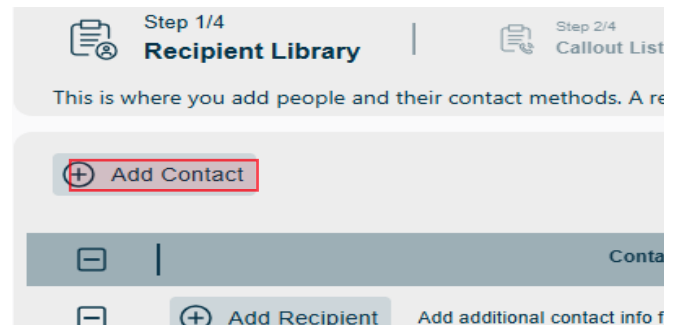

**5.1.5.** Set a phone number, email address, text/SMS for each contact. If the person is going to receive multiple methods of contact such as email and text, you will need to set up each method.

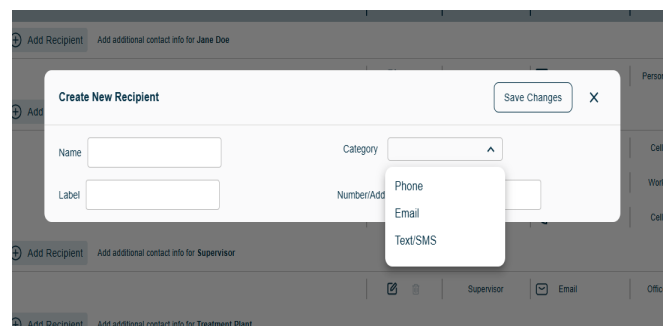

## Create Callout List

**5.1.6.** Next, use the arrows to navigate to the callout list. select a Callout List or create a new one by clicking the “create new list” at the top of the left column. When the dialogue box opens, type in the name of the call out list that you wish to create.

Click the “Create Default Schedule” slider button to automatically create a callout schedule for the callout list you are making. In section 5.2 we will review and edit the callout schedule. Click the “save changes” button to proceed to next step.

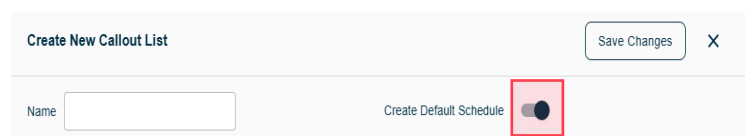
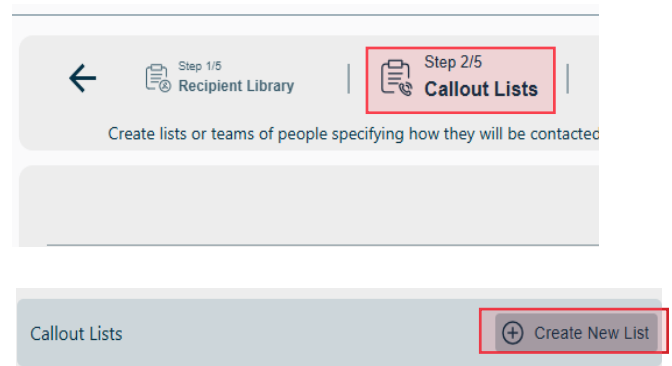

# Crystal Ball Kit

## Comprehensive User Guide

**5.1.8.** Once the List is added three methods of contact will be automatically populated. You can add and change recipients by clicking the pencil icon on each entry and adding recipients from the Recipient Library. Users may also specify the number of retries and the time delay (in minutes) after each entry.

**NOTE:** The entire list will be called once before the retry sequence begins. Recipients are contacted in the order shown with #1 contacted first. To change the order of the list, click the three lines on the right of an entry and drag up or down.

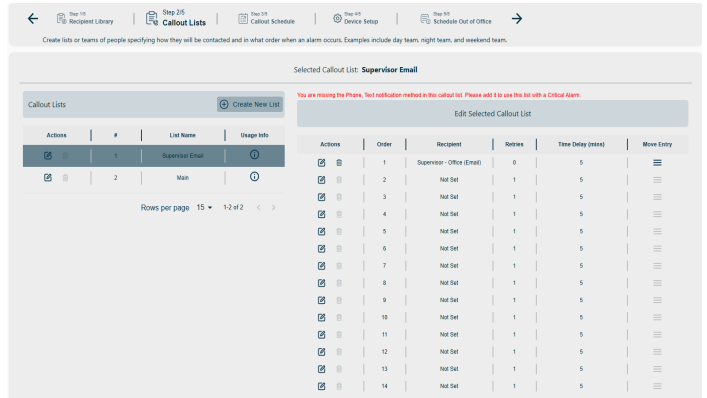

**5.1.9** Once users have finished editing an entry, make sure to click "save changes".

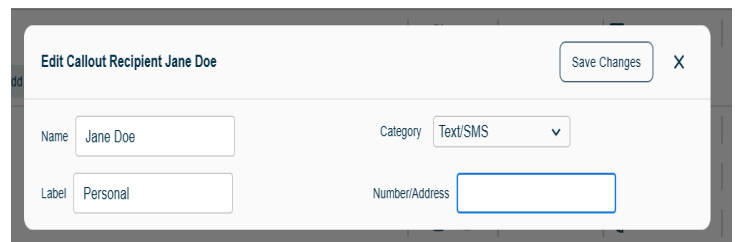

**Tip:** You can use the same recipients in a variety of lists. Try creating a list with the same recipients in a different order. This can make changing between callout orders very easy when adjusting your on-call schedule.

## 5.2 Create Callout Schedule

**5.2.1.** Using the navigation arrow go to "Callout Schedule"

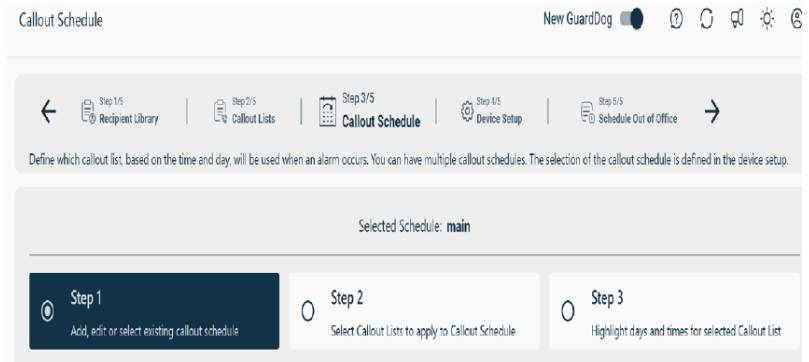

# Crystal Ball Kit

## Comprehensive User Guide

**5.2.3.** Before moving on, click on the call out schedule that you wish to add call out lists to.

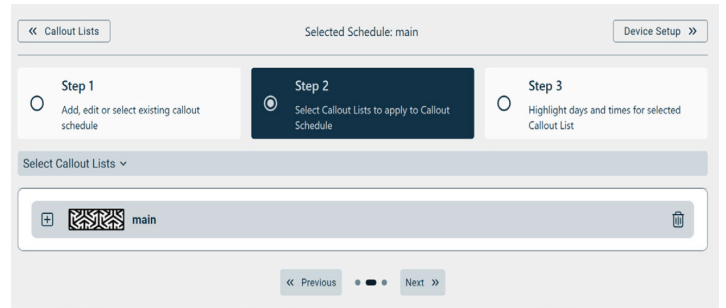

Then, click on the “Step 2” box to apply a “callout list” to “call out schedule”. Click on long horizontal bar “select callout lists” to add a call out list from the drop-down. You can then check the check boxes of the lists that you want to add to the call out schedule. When you are done click the “close button in bottom right of dialogue box.

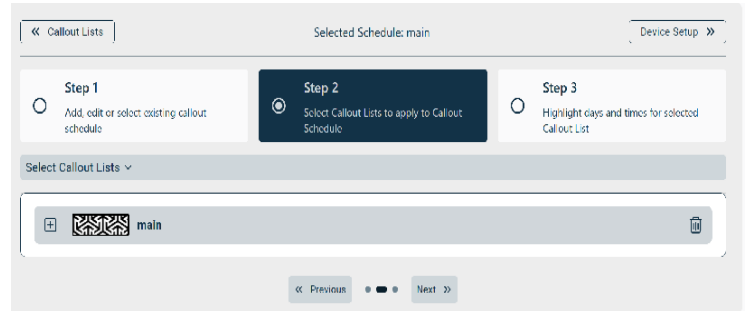

**5.2.4.** Now click the “Step 3” box and you should see a screen with 168 boxes. In this table you select when you want the call out list to be used during times of the day, and days of the week.

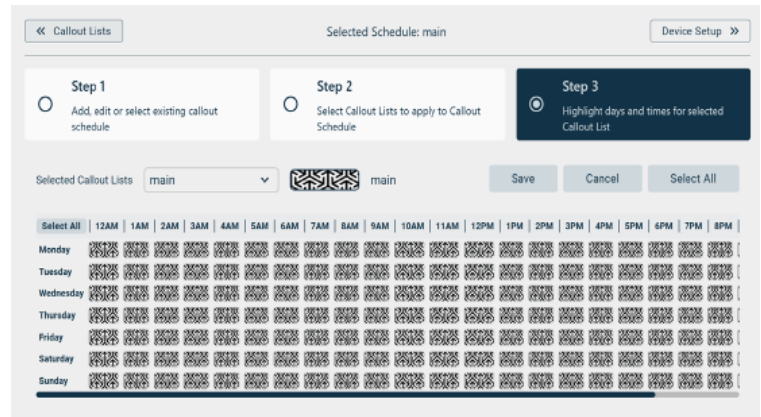

Each call out list will have its own color and scheme. Select which callout list to start populating in the hours and days boxes next to where it says “Selected Call Out Lists”.

Then you can select boxes one at a time, click and drag, or select the “select all” button to the far right of the page.

**5.2.5.** After selecting a color for all 168 boxes, a “save” button will appear. Click on the button to save your work.

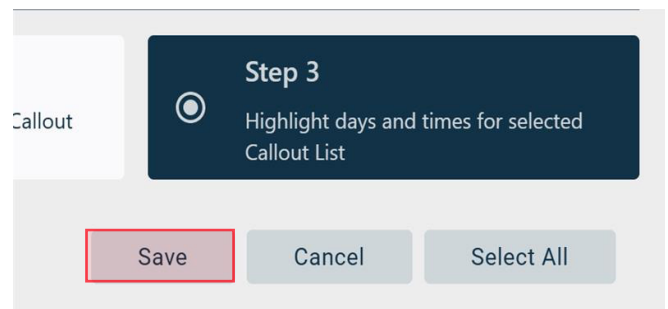

# Crystal Ball Kit

## Comprehensive User Guide

### 5.3 Device Setup- Mandatory Step

**5.3.1.** Using the navigation buttons at the top of the screen, click "Device Setup".

(Or you can navigate to the Device Setup page using the navigation bar on the left.)

**5.3.2.** Use the "Station Selection" dropdown to pick the station you want to setup.

**5.3.3.** Locate the Station Information box. Click the pencil button to edit the information in the box.

#### Example:

NAME: Station Name

Station Number: Customer Discretion

Address: You can enter the complete address or if you have the GPS Coordinates you can check the Coordinate Override box and enter the Latitude and Longitude. (if you do not put an address the station will not show on the map view.)

#### 5.3.1. DIGITAL INPUTS

Use the provided example to configure your digital inputs, if you wired your unit according to the table on page 21

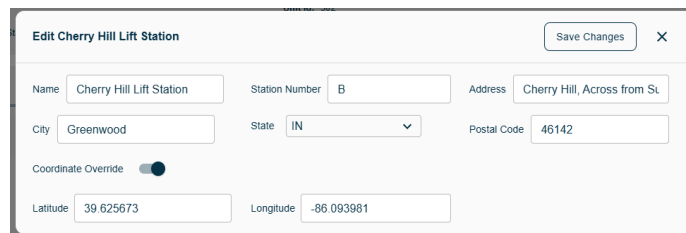
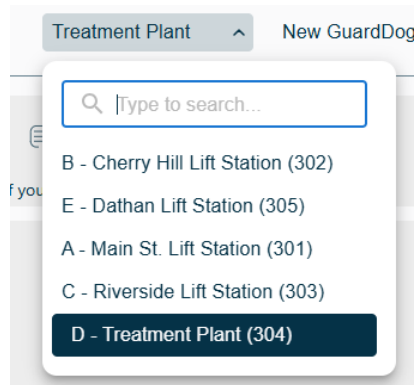
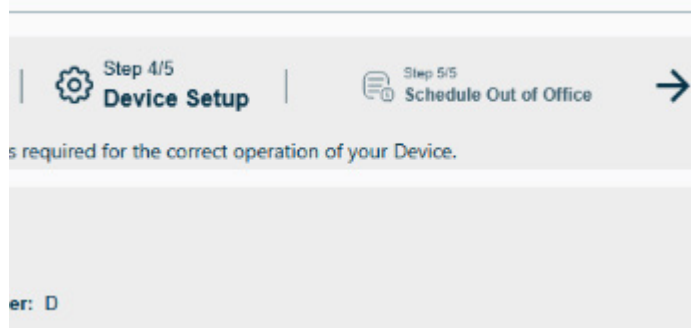

**Example:** Input 1 should always be a High Wet Well Level Alarm and Input 2 will always be Pump 1 Overload and so on. This is the way the inputs are wired on your terminal blocks in your Crystal Ball unit. Shown on page #21

DIGITAL INPUTS											
Actions	Input Number	Show	Description	Alarm State	Notify When	Callout Schedule	Style	Pwr Suppress	Simulate Notification		
<input checked="" type="checkbox"/> <input type="checkbox"/>	1	<input checked="" type="checkbox"/>	High Wet Well Level	On (Normally Open)	Alarm & Normal	Main Callout Plan	Alarm	<input type="checkbox"/>	<input type="checkbox"/>		
<input checked="" type="checkbox"/> <input type="checkbox"/>	2	<input checked="" type="checkbox"/>	Pump 1 Overload	On (Normally Open)	Alarm & Normal	Main Callout Plan	Alarm	<input type="checkbox"/>	<input type="checkbox"/>		
<input checked="" type="checkbox"/> <input type="checkbox"/>	3	<input checked="" type="checkbox"/>	Pump 2 Overload	On (Normally Open)	Alarm & Normal	Main Callout Plan	Alarm	<input type="checkbox"/>	<input type="checkbox"/>		
<input checked="" type="checkbox"/> <input type="checkbox"/>	4	<input checked="" type="checkbox"/>	Phase Failure	On (Normally Open)	Alarm & Normal	Main Callout Plan	Alarm	<input type="checkbox"/>	<input type="checkbox"/>		
<input checked="" type="checkbox"/> <input type="checkbox"/>	5	<input checked="" type="checkbox"/>	Low Wet Well Level	On (Normally Open)	Alarm & Normal	Main Callout Plan	Alarm	<input type="checkbox"/>	<input type="checkbox"/>		
<input checked="" type="checkbox"/> <input type="checkbox"/>	6	<input checked="" type="checkbox"/>	Low Boxide Level	On (Normally Open)	Alarm & Normal	Main Callout Plan	Alarm	<input type="checkbox"/>	<input type="checkbox"/>		
<input checked="" type="checkbox"/> <input type="checkbox"/>	7	<input checked="" type="checkbox"/>	Input 7	On (Normally Open)	Never	None	Alarm	<input type="checkbox"/>	<input type="checkbox"/>		
<input checked="" type="checkbox"/> <input type="checkbox"/>	8	<input checked="" type="checkbox"/>	Pump 1 Seal Failure	On (Normally Open)	Alarm & Normal	Main Callout Plan	Alarm	<input type="checkbox"/>	<input type="checkbox"/>		
<input checked="" type="checkbox"/> <input type="checkbox"/>	9	<input checked="" type="checkbox"/>	Pump 2 Seal Failure	On (Normally Open)	Alarm & Normal	Main Callout Plan	Alarm	<input type="checkbox"/>	<input type="checkbox"/>		
<input checked="" type="checkbox"/> <input type="checkbox"/>	10	<input checked="" type="checkbox"/>	Tamper Switch	On (Normally Open)	Alarm & Normal	Main Callout Plan	Alarm	<input type="checkbox"/>	<input type="checkbox"/>		
<input checked="" type="checkbox"/> <input type="checkbox"/>	11	<input checked="" type="checkbox"/>	Input 11	On (Normally Open)	Never	None	Alarm	<input type="checkbox"/>	<input type="checkbox"/>		

# Crystal Ball Kit

## Comprehensive User Guide

**5.2.3.** If the panel you are wiring into doesn't have the capability to wire one or more of these alarms such as a Pump 1 Seal Failure Alarm or a Low Wet Well Level Alarm, etc., leave that input blank.

**NOTE:** If your panel does have all the capabilities listed under the wiring section inputs, then make sure you use the correct label for each input.

DIGITAL INPUTS			RUNTIME INPUTS	GENERAL ALARMS	ANALOG INPUTS	DIGITAL OUTPUTS			
Actions	Input Number	Show	Description	Alarm State	Notify When	Callout Schedule	Style	Pwr Suppress	Simulate Notification
	1	<input checked="" type="checkbox"/>	High Wet Well Level	On (Normally Open)	Alarm & Normal	Main Callout Plan	Alarm	<input type="checkbox"/>	
	2	<input checked="" type="checkbox"/>	Pump 1 Overload	On (Normally Open)	Alarm & Normal	Main Callout Plan	Alarm	<input type="checkbox"/>	
	3	<input checked="" type="checkbox"/>	Pump 2 Overload	On (Normally Open)	Alarm & Normal	Main Callout Plan	Alarm	<input type="checkbox"/>	
	4	<input checked="" type="checkbox"/>	Phase Failure	On (Normally Open)	Alarm & Normal	Main Callout Plan	Alarm	<input type="checkbox"/>	
	5	<input checked="" type="checkbox"/>	Low Wet Well Level	On (Normally Open)	Alarm & Normal	Main Callout Plan	Alarm	<input type="checkbox"/>	
	6	<input checked="" type="checkbox"/>	Low Boxide Level	On (Normally Open)	Alarm & Normal	Main Callout Plan	Alarm	<input type="checkbox"/>	
	7	<input checked="" type="checkbox"/>	Input 7	On (Normally Open)	Never	None	Alarm	<input type="checkbox"/>	
	8	<input checked="" type="checkbox"/>	Pump 1 Seal Failure	On (Normally Open)	Alarm & Normal	Main Callout Plan	Alarm	<input type="checkbox"/>	
	9	<input checked="" type="checkbox"/>	Pump 2 Seal Failure	On (Normally Open)	Alarm & Normal	Main Callout Plan	Alarm	<input type="checkbox"/>	
	10	<input checked="" type="checkbox"/>	Tamper Switch	On (Normally Open)	Alarm & Normal	Main Callout Plan	Alarm	<input type="checkbox"/>	
	11	<input checked="" type="checkbox"/>	Input 11	On (Normally Open)	Never	None	Alarm	<input type="checkbox"/>	

**Notify When** - Set all to Alarm and Normal condition.

Alarm State	Notify When	Callout Schedule
On (Normally Open)	Alarm & Normal	Main Callout Plan
On (Normally Open)	Alarm & Normal	Main Callout Plan
On (Normally Open)	Alarm & Normal	Main Callout Plan
On (Normally Open)	Alarm & Normal	Main Callout Plan
On (Normally Open)	Alarm & Normal	Main Callout Plan
On (Normally Open)	Alarm & Normal	Main Callout Plan

**Power Suppress** - The "Pwr Suppress" can be checked for inputs that go into alarm when power is lost.

Examples:

- Pump 1 Overload,
- Pump 2 Overload,
- Phase Failure,
- Pump 1 Seal Failure
- Pump 2 Seal Failure.

This will stop you from getting multiple notifications when power is lost.

Style	Pwr Suppress	Simulate Notification
Alarm	<input type="checkbox"/>	
Alarm	<input type="checkbox"/>	
Alarm	<input type="checkbox"/>	
Alarm	<input type="checkbox"/>	
Alarm	<input type="checkbox"/>	
Alarm	<input type="checkbox"/>	
Alarm	<input type="checkbox"/>	

**TIP:** The Power Suppress feature disables notifications from that input during a power failure. While the input still goes into alarm, it will not send out notifications. For this feature to work as designed, the input's time delay must be longer than the power failure alarm delay (both configured in the device).

# Crystal Ball Kit

## Comprehensive User Guide

### 5.3.4. RUNTIME INPUTS

Runtime Inputs provide you with data on Pump Calculations page. They can also provide you with an excess runtime notification (or pump failure notifications when using a device with pump control enabled).

DIGITAL INPUTS			RUNTIME INPUTS		GENERAL ALARMS		ANALOG INPUTS		DIGITAL OUTPUTS			
Actions	Input	Show	Description	Runtime Notification	Insufficient Runtime Setpoint in Minutes	Excessive Runtime Setpoint in Minutes	Pump Fail Notification	Callout Schedule	Pwr Suppress	Excessive Pump Cycle Notification	Excessive Pump Cycle Setpoint	
	12	<input checked="" type="checkbox"/>	Pump 1	Excessive Runtime Only	Disabled	120	Alarm & Normal	Main Callout Plan	<input type="checkbox"/>	Notify	50	
	13	<input checked="" type="checkbox"/>	Pump 2	Excessive Runtime Only	Disabled	120	Alarm & Normal	Main Callout Plan	<input type="checkbox"/>	Notify	50	
	14	<input checked="" type="checkbox"/>	Pump 3	Excessive Runtime Only	Disabled	120	Alarm & Normal	Main Callout Plan	<input type="checkbox"/>	Notify	50	

#### Input -

This is a read only field that indicates the physical number of the input on the device and is provided for your reference.

Input	Show	Description
12	<input checked="" type="checkbox"/>	Pump 1
13	<input checked="" type="checkbox"/>	Pump 2
14	<input checked="" type="checkbox"/>	Pump 3

#### Insufficient & Excessive Runtime -

Excess Runtime allows you to set up a Maximum amount of runtime for a given input for a 24-hour period. This field is entered in minutes and will cause any runtime reading over this amount to be flagged in red on the Pump Calculations page. You can also receive notifications when this maximum is exceeded by using the Excess Notification column.

Runtime Notification	Insufficient Runtime Setpoint in Minutes	Excessive Runtime Setpoint in Minutes
Excessive Runtime Only	Disabled	120
Excessive Runtime Only	Disabled	120
Excessive Runtime Only	Disabled	120

# Crystal Ball Kit

## Comprehensive User Guide



### GPM Override -

This column allows you to turn GPM Override on or off. GPM override allows you to replace any value from the device with the value provided in the GPM Rating column. This is very helpful for stations with non-standard wet well dimensions that couldn't be or weren't entered in the device, or for pumps whose GPM rating is above our maximum reading (see your user manual for more information).

Excessive Pump Cycle Notification	Excessive Pump Cycle Setpoint	GPM Override
Never	Disabled	Off
Never	Disabled	Off
Never	Disabled	Off

### GPM Rating -

This is the value that is used for all pump calculations when the GPM Override feature is turned On.

GPM Override	GPM Override Rating	Simulate Notification
Off	NA	
Off	NA	
Off	NA	

# Crystal Ball Kit

## Comprehensive User Guide

### 5.3.5. GENERAL ALARMS

General Alarms are alarms for the following situations:

DIGITAL INPUTS		RUNTIME INPUTS		GENERAL ALARMS		ANALOG INPUTS		DIGITAL OUTPUTS	
Actions	Show	Description	Notify When	Callout Schedule	Settings	Simulate Notification			
	<input checked="" type="checkbox"/>	Primary Power	1. Alarm & Normal	Main Callout Plan					
	<input checked="" type="checkbox"/>	Battery Status	2. Alarm (< 12v)	Main Callout Plan					
	<input checked="" type="checkbox"/>	Signal Strength	3. Never	None					
	<input checked="" type="checkbox"/>	Maintenance Key	4. Enabled & Disabled	Supervisor Email Callout Plan					
	<input checked="" type="checkbox"/>	Communication Check	5. Alarm & Normal	Main Callout Plan	After 2 Hours				

#### 1. Primary Power -

This will notify you if the main power for the device has been lost. This should always be set as alarm and normal condition and should be set to notify your Critical Call Plan.

#### 2. Battery Status -

This alarm allows you to be notified if and when your device's battery voltage falls below an acceptable level. This should be set to Alarm and Normal and set to notify your Non-Critical Call Plan.

#### 3. Signal Strength -

This alarm allows you to be notified if and when your device's cellular signal strength falls below an acceptable level. If your device has an unacceptable signal strength, device communications are not guaranteed, and alarm notifications may not be processed. This should always be set as Alarm and Normal, and should be set to notify your Critical Call Plan.

#### 4. Maintenance Key -

This alarm allows you to be notified when a device is enabled/disabled using a maintenance key at the station. When a device is disabled, no alarm notifications will be processed. This should be set to Disable and set to notify your Non-Critical Call Plan.

#### 5. Communication Check -

This notification allows you to be notified if a device fails to communicate within a certain time frame. You may choose a setting of either Off, 1 Hour, 30 Hours, or 60 Hours. The hour amount is the amount of time since the device last called in. This means that if you select 30 hours, this alarm will occur after a device has failed to communicate for 30 hours. 1 Hour should only be selected for units that are using the 5- or 15-minute reporting Wireless Plan. This should be set as alarm and should be set to notify your Critical Call Plan.

# Crystal Ball Kit

## Comprehensive User Guide

### 5.3.6. ANALOG INPUTS

Use the sample below to configure your analog inputs. ALL CRYSTAL BALL UNITS SHOULD BE CONFIGURED THIS WAY.

**Example:** Input 1 will always be I-Level, Input 2 will always be Pump 1 Amps and Input 3 will be Pump 2 Amps. This is the way the inputs are wired on your terminal blocks on your Crystal Ball unit. See page #22

DIGITAL INPUTS			RUNTIME INPUTS			GENERAL ALARMS			ANALOG INPUTS			DIGITAL OUTPUTS		
Actions	Input	Show	Description	Low 4 mA	High 20 mA	Units	Low Alert	High Alert	Normal Alert	Callout Schedule	Offset Value	Pwr Suppress	Simulate Notification	
	1	<input checked="" type="checkbox"/>	Well Level	0.00	20.00	ft	<input checked="" type="checkbox"/>	<input checked="" type="checkbox"/>	<input checked="" type="checkbox"/>	Main Callout Plan	0.00	<input type="checkbox"/>		
	2	<input checked="" type="checkbox"/>	Pump 1 Current	0.00	100.00	Amps	<input checked="" type="checkbox"/>	<input checked="" type="checkbox"/>	<input type="checkbox"/>	Main Callout Plan	0.00	<input type="checkbox"/>		
	3	<input checked="" type="checkbox"/>	Pump 2 Current	0.00	100.00	Amps	<input checked="" type="checkbox"/>	<input checked="" type="checkbox"/>	<input type="checkbox"/>	Main Callout Plan	0.00	<input type="checkbox"/>		
	4	<input checked="" type="checkbox"/>	Pump 3 Current	0.00	100.00	Amps	<input checked="" type="checkbox"/>	<input checked="" type="checkbox"/>	<input type="checkbox"/>	Main Callout Plan	0.00	<input type="checkbox"/>		

- 1.
- 2.
- 3.
- 4.
- 5.
- 6.

#### 1. Low 4 mA -

This is the scaling low end equivalent to a reading of 4 milliamps. Our level transducer is 0 to 20', so 4mA should be set to 0.00.

#### 2. High 20 mA -

This is the scaling high end equivalent to a reading of 20 milliamps. Our level transducer is 0 to 20', so 20mA should be set to 20.00.

#### 3. Units -

This is the unit of measurement for your analog input For analog input #1 set this to feet, and analog inputs 2,3,4 set to amps.

#### 4. Low Alert -

This indicates if you would like to be notified when your input's reading falls below the low alarm set point configured within the device.

#### 5. High Alert-

This indicates if you would like to be notified when your input's reading rises above the high alarm set point configured within the device.

#### 6. Normal Alert -

This indicates if you would like to be notified when your input's reading returns from either high or low alarm

# Crystal Ball Kit

## Comprehensive User Guide

### Offset Value -

The amount to offset the readings for the input. The analog offset is entered positively but is subtracted from the final value.

**NOTE:** This is rarely used, but a good example would be for a water tower. You may want to know the level of the water - but only at the top (not the stem). The level probe would return a value between 0 and 200 ft (which would include the stem). If the stem is 80 feet you would enter that as an offset and the reading would always be between 0 and 120 ft (0 would be given for an actual reading of 80).

In this case, you should have entered your scaling as 0 to 200 feet and their offset as 80.

Callout Schedule	Offset Value	Pwr Suppress
None	0.00	<input type="checkbox"/>
None	0.00	<input type="checkbox"/>
None	0.00	<input type="checkbox"/>
None	0.00	<input type="checkbox"/>

**Congratulations!** This completes your Crystal Ball basic monitoring setup. If you desire to use the below advanced features, simply scan the QR code for the full online manual, which will also include instructional videos.

### Advanced Features

- Pump On/Off level control
- Peer-to-Peer wireless control
- Optional wiring diagrams
- Monitoring pulse counters or rain gauge
- Troubleshooting table
- OmniSite training
- And more!



Scan here for  
Virtual Manual

---

# ADVANCED FEATURES

---

# Crystal Ball Kit

## Comprehensive User Guide

### Using Cellular for Peer-to-Peer Control in Real Time

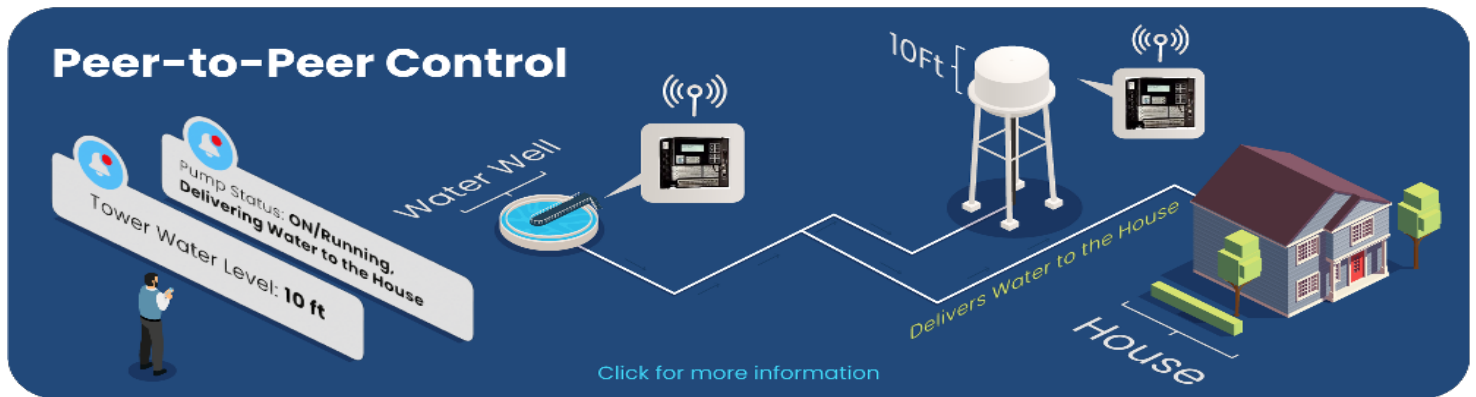

Did you know that OmniSite's Crystal Ball uses the power of the internet and cellular networks to control complex interactions between pump stations and water towers for municipal water or wastewater facilities?

## NEW FEATURES

- **Peer-to-Peer Control:** Devices like the Crystal Ball can now communicate directly to take immediate action, such as stopping pumps when high-level alarms are triggered.
- **Real-Time Reporting:** Monitor and manage your systems with live updates accessible from any devices- tablet, PC, or phone-through the OmniSite GuardDog interface.
- **Enhanced Responsiveness:** Experience improved system efficiency with real-time communication, helping you prevent issues before they arise.

# Crystal Ball Kit

## Comprehensive User Guide

**New Peer-To-Peer Control- Easy to use Control table- No programming required!**

Peer-To-Peer Control New GuardDog

PEER CONTROL RULES		RULE EXECUTION STATUS			PUMP ALTERNATORS						
Station From	Input Type	Input	Condition	Compare Value	Station To	Output	Output State	Pump Alternator Scheme	Callout Schedule	Retry	Actions
40486	Analog Input	Analog 1	>	80			On	Jeff Test	Emanuel Plan	3	
40486	Analog Input	Analog 1	<	70			Auto	Jeff Test	Emanuel Plan	3	
40949	Digital Input	Input 1	=	On	40949	Output 2	On		Test Button	2	
40949	Digital Input	Input 1	=	Off	40949	Output 2	Off		Test Button	2	
40937	Digital Input	Input 2	=	On	40486	Output 3	On		Test Button	1	
40937	Digital Input	Input 2	=	Off	40486	Output 3	Off		Test Button	1	
40485	Digital Input	Input 1	=	On	20251	Output 3	Auto		Emanuel Plan	2	
40485	Digital Input	Input 1	=	Off	20251	Output 3	Off		Emanuel Plan	2	
39154	Digital Input	Input 2	=	On	20251	Output 3	On		Test Button	2	
39154	Digital Input	Input 2	=	Off	20251	Output 3	Off		Test Button	2	

OmniSite’s sample Peer-To-Peer control table is powerful and completely eliminates complex programming- Let the Pro’s at OmniSite Peer-to-Peer for you for a low cost fee- saves time and confusion

OmniSite’s Peer-To-Peer control provides Real-Time Reporting on your pumps, so you can easily see when each pump runs in a graphical format



# Crystal Ball Kit

## Comprehensive User Guide

Additional Peer-to-Peer features show status, cycles, runtime, and total station flow using timed drawdowns, eliminating the need for physical flow meters using volumetric calculations

**Device: 30842 | Crystal Ball**

Date	Report Reason	State			Cycles			Runtime			Flow Rate (GPM)		
		Pump 1	Pump 2	Pump 3	Pump 1	Pump 2	Pump 3	Pump 1	Pump 2	Pump 3	Pump 1	Pump 2	Pump 3
2/25/25, 11:49 PM	TSR	Off	Off	Off	0	0	0	0m 0s	0m 0s	0m 0s	43	39	37
2/25/25, 11:45 PM	Pump State Change	Off	Off	Off	0	0	0	0m 0s	0m 0s	0m 29s	43	39	37
2/25/25, 11:44 PM	Pump State Change	Off	Off	On	0	0	1	0m 0s	0m 0s	0m 3s	43	39	37
2/25/25, 11:34 PM	TSR	Off	Off	Off	0	0	0	0m 0s	0m 0s	0m 0s	43	39	37
2/25/25, 11:28 PM	Pump State Change	Off	Off	Off	0	0	0	0m 0s	0m 27s	0m 0s	43	39	37
2/25/25, 11:27 PM	Pump State Change	Off	On	Off	0	1	0	0m 0s	0m 3s	0m 0s	43	39	37
2/25/25, 11:19 PM	TSR	Off	Off	Off	0	0	0	0m 0s	0m 0s	0m 0s	43	39	37
2/25/25, 11:10 PM	Pump State Change	Off	Off	Off	0	0	0	0m 22s	0m 0s	0m 0s	43	39	37
2/25/25, 11:10 PM	Pump State Change	On	Off	Off	1	0	0	0m 3s	0m 0s	0m 0s	43	39	37
2/25/25, 11:04 PM	TSR	Off	Off	Off	0	0	0	0m 0s	0m 0s	0m 0s	43	39	37
2/25/25, 10:53 PM	Pump State Change	Off	Off	Off	0	0	0	0m 0s	0m 0s	0m 25s	43	39	37
2/25/25, 10:53 PM	Pump State Change	Off	Off	On	0	0	1	0m 0s	0m 0s	0m 8s	43	39	37
2/25/25, 10:49 PM	TSR	Off	Off	Off	0	0	0	0m 0s	0m 0s	0m 0s	43	39	37

## NEW

### Real-time Reporting & Audit Logs

- Digital and Pump status report instantly
- Analogs report at 5 minutes unless cross user defined filter value, then instant

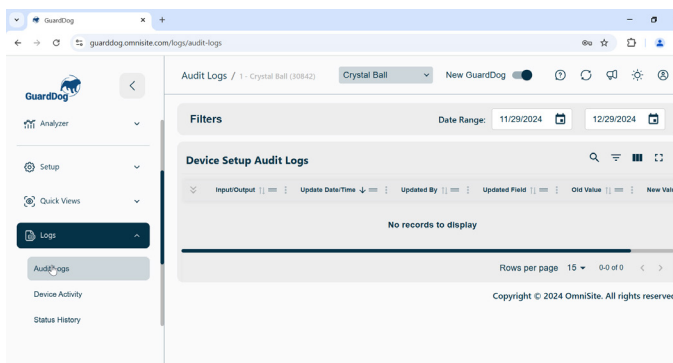
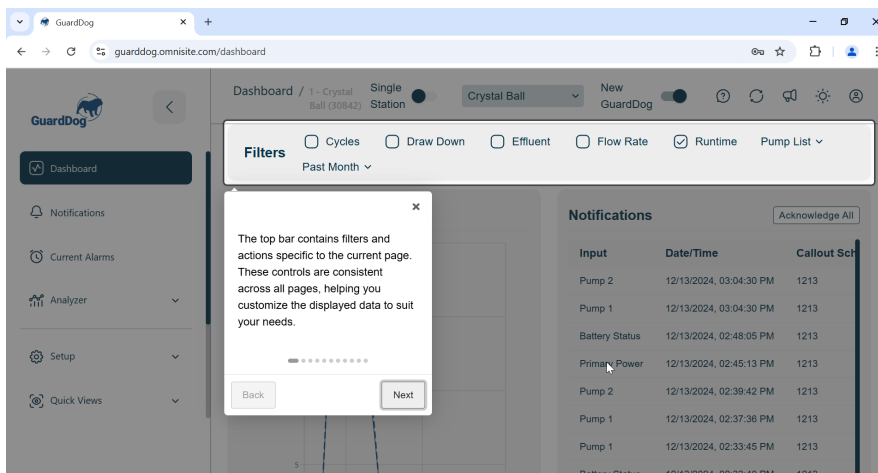

\*See your OmniSite sales representative for our Real-time reporting package\*

# Crystal Ball Kit

## Comprehensive User Guide

### OmniSite Audit Trail For System Security

Audit Logs / OmniBeacon (30884) OmniBeacon New GuardDog

Filters Date Range: 02/06/2025 - 03/31/2025

#### Device Setup Audit Logs

Station Information	Input/Output	Update Date/Time	Updated By	Updated Field	Old Value	New Value
Crystal Ball (30842)	Analog Input 1	Fri - 2/28/25, 4:19 PM	OmniSite Tech Support	Units	in	ft
Crystal Ball (30842)	Analog Input 1	Fri - 2/28/25, 4:19 PM	OmniSite Tech Support	High 20 mA	100.00	20.00
5 - Pump Control P2P Testing (36762)	Digital Output 1	Fri - 2/28/25, 3:47 PM	OmniSite Tech Support	Description	Pump 2	Pump 1
5 - Pump Control P2P Testing (36762)	Digital Output 1	Fri - 2/28/25, 3:46 PM	OmniSite Tech Support	Description	Output 1	Pump 2
Crystal Ball (30842)	Digital Input 1	Thu - 2/27/25, 5:12 PM	OmniSite Tech Support	Callout Schedule	None	Zach W
Crystal Ball (30842)	Digital Input 1	Thu - 2/27/25, 5:12 PM	OmniSite Tech Support	Notify When	Never	Alarm
Crystal Ball (30842)	Runtime Input 2	Fri - 2/14/25, 10:56 AM	OmniSite Tech Support	GPM Override	On	Off
Crystal Ball (30842)	Runtime Input 1	Fri - 2/14/25, 10:56 AM	OmniSite Tech Support	GPM Override	On	Off

Rows per page 15 1-8 of 8

Copyright © 2024 - 2025 OmniSite. All rights reserved.

**\*Product security is a big issue these days, your OmniSite system lets you know who made changes 24/7/365\***

Dashboard / Multiple Stations Selected Multi Station Station Group New GuardDog

Filters Past Week

#### Pump Calculations / 1 Week Averages

Stations	Cycles			Drawdown			Flow Rate			Runtime		
	Pump-1	Pump-2	Pump-3	Pump-1	Pump-2	Pump-3	Pump-1	Pump-2	Pump-3	Pump-1	Pump-2	Pump-3
Crystal Ball	0	0	0	0%	0%	0%	0	0	0	0%	0%	0%
Pump Control P2P Testing	0	0	0	0%	0%	0%	0	0	0	0%	0%	0%
XR50	0	0	0	0%	0%	0%	0	0	0	0%	0%	0%

#### Map View

68°F | Isolated Storms | 0.282 in/hr Rain

Indianapolis

#### Notifications

Station	Input	Date/Time	Callout Schedule	Acked	Ack Info
No notifications to display					

#### Current Alarms

Station	Input Type	Description	Date/Time	Status
XR50	General	Power Failure	03/28/2025, 02:23:52 PM	🔴
OmniBeacon	General	Low Battery	03/26/2025, 09:21:03 AM	🔴

OmniSite's GuardDog web interface connects with weather service to show you when the next big storm is coming- the amount of rainfall at EACH pump station, the effect on each station's inflow rate, and pump operation!

# Crystal Ball Kit

## Comprehensive User Guide

The new Radar Weather overlay will show rainfall amounts at each individual pump station

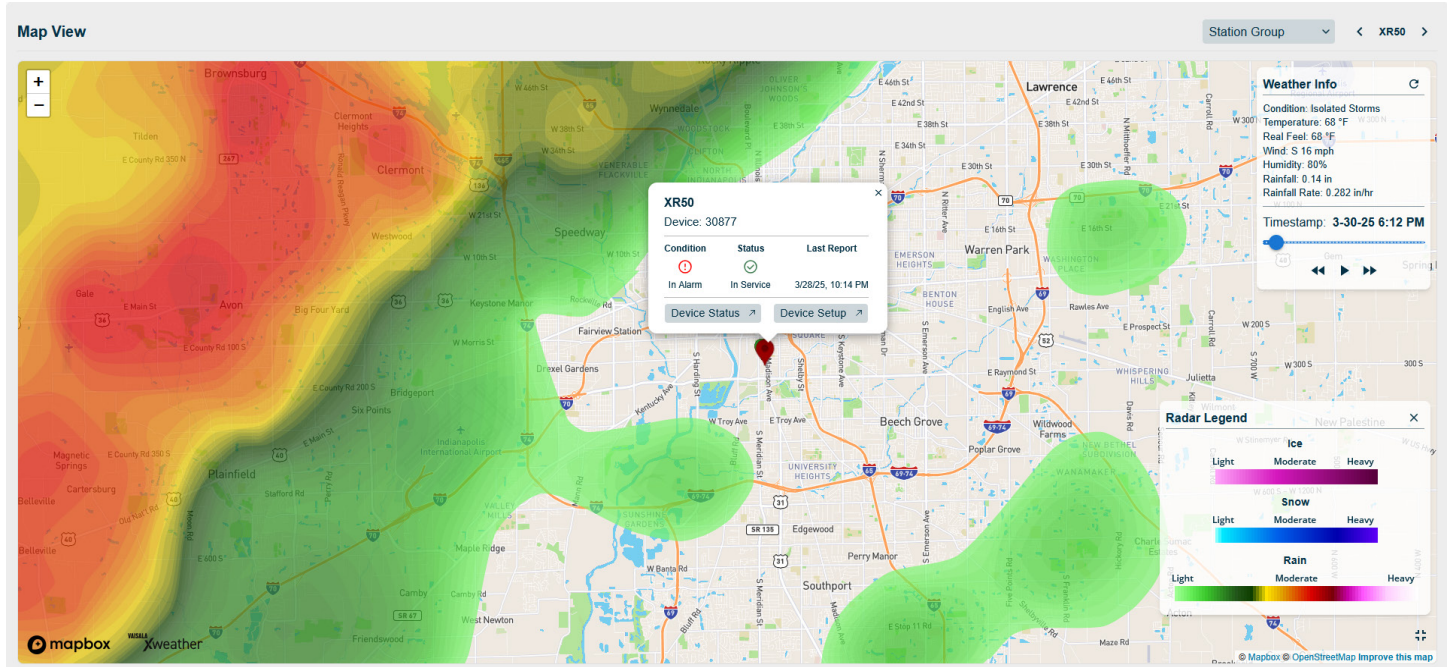

## Pump Station Monitoring From Anywhere 24/7/365

All of OmniSite's products can be mixed/matched within your system for a cost-effective solution

**OmniBeacon-** For small Stations

**XR50-** For Mid Size stations

**Crystal Ball-** For our Complete Pump Station Solution

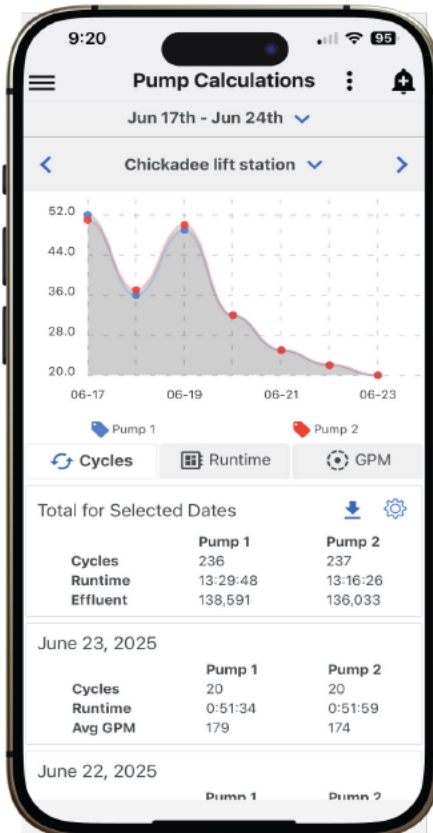

Included iPhone and Android phone apps allow you to keep track of operations anywhere and anytime

# Crystal Ball Kit

## Comprehensive User Guide

### Pump Station Monitoring

---

After You Receive a High-Level Alarm- How Much Time Do You Really Have?

Assume:  
 6' Diameter Wet Well  
 Surface to HWA = 15'  
 Inflow Rate = 250 GPM  
 All Pumps Inoperable

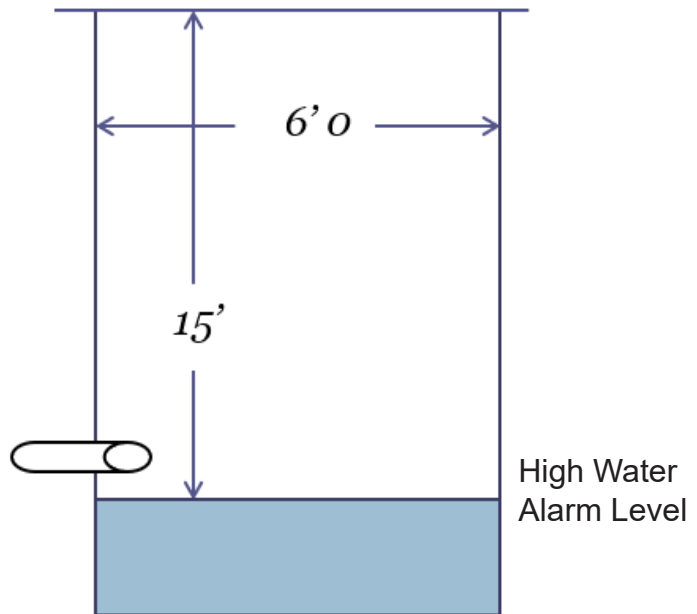

Wet Well Volume above HWA	=	3,170 Gallons
Volume in Upstream Sewer	=	1,000 Gallons
Total Available Volume	=	4,170 Gallons
Inflow Rate	=	250 GPM

$$\frac{4170 \text{ Gal}}{250 \text{ GPM}} = \mathbf{16.7 \text{ Minutes}}$$

\*Ask yourself- Can your facility afford to sit a person in a lawn chair 24/7/365 to watch a pump station? Your OmniSite monitors every second of the day to give you the best chance to respond to this situation, as you don't have much time to respond

# Crystal Ball Kit

## Comprehensive User Guide

### Pump Station Monitoring

---

#### Volumetric Flow Measurement/Drawdown Test Used by OmniSite Monitors- How It works

$$\text{Pumping Rate} = \text{Drawdown Rate} + \text{Fill Rate}$$

$$\text{Flow} = \frac{\text{Volume}}{\text{Time}} + \frac{\text{Gallons}}{\text{Minute}}$$

Change of level in a wet well of known volume measured against time

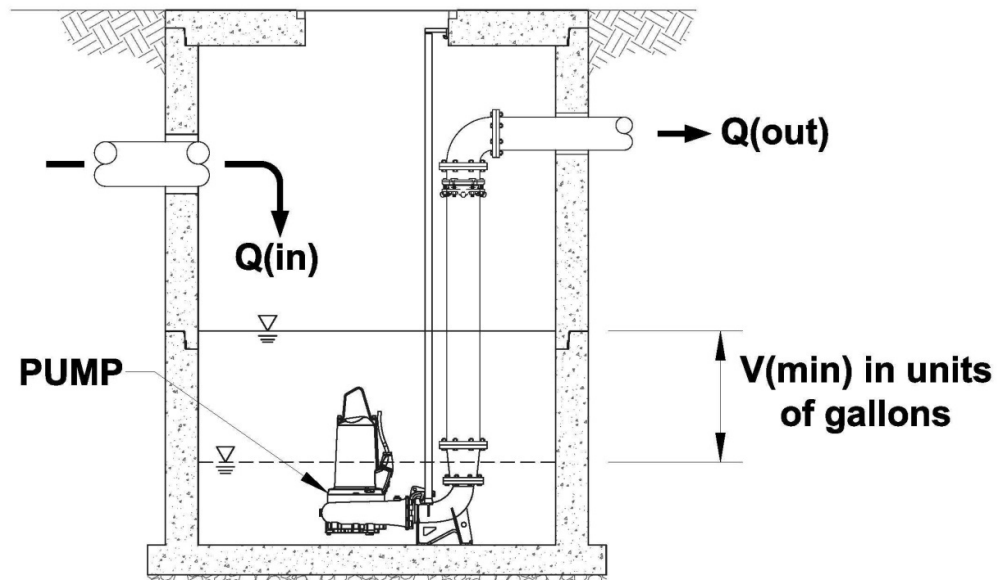

# Crystal Ball Kit

## Comprehensive User Guide

### Advantages Of Volumetric Flow Measurement

---

- Inexpensive
- Accurate Under Most Conditions
- No Space Requirement
- Easy to Install

### Limitations of Volumetric Flow Measurement

---

- Wet Well Volume Must be Accurate
- Inflow Cannot Exceed pumping rate of one pump
- Constant speed pumps only (no VFD's)
- Should not be used for billing purposes
- Soft starts are less accurate as ramp up and ramp down times are increased

---

# PEER TO PEER CONTROL INSTRUCTIONS

---

# Crystal Ball Kit

## Comprehensive User Guide

### Overview

The OmniSite Peer to Peer (P2P) control is a way to use digital and Analog inputs on one unit to provide basic control of the outputs on a different unit. This is available as part of the 5-minute reporting / Peer to Peer service plan.

Basic Configuration of the P2P control is done through simple P2P rules. No programming necessary. They consist of the following rule types:

- **Analog control rules**

Analog rules will turn an output on or off based upon an analog value and whether it is above or below the setpoint

- **Digital control rules**

Digital control rules will turn an output on or off based upon the state of an input. The digital rule can be configured for either one or two inputs. The two-input mode is used for a latching type control sequence that is often used in pump level control

- **Pump Alternators**

The pump alternator allows for multiple outputs to be alternated or rotated to ensure even distribution of the output operations

Any OmniSite unit can be used for the input. OmniBeacon, XR50, or Crystal Ball. Only the Crystal Ball (at this time) has relays and the ability to turn a piece of equipment on or off.

The OmniSite P2P control is suitable for systems that is lag or time tolerant. This means that the triggering and response commands do not occur instantaneously. Normal response is anywhere from 30 seconds to several minutes from the time a trigger is initiated to when the output is operated. A typical application would be the operation of the pumps feeding a water tower where instantaneous control is not required.

### Requirements

Any units that will be part of P2P control will need the newest firmware and setup with P2P service plan. Please contact your sales representative or our technical support to set this up. Once that has been done, the units can then be used for the P2P control.

### Setting up the P2P control

Depending upon the system you are trying to control, you must decide what type of signal you are going to use for control, analog or digital. A P2P control rule will then need to be configured accordingly.

# Crystal Ball Kit

## Comprehensive User Guide

### 1. Creation of the rules

- a. In the left panel of New GuardDog and the menu selection, is the setup selection.
- b. Click on the down arrow to open the Setup menu selection.
- c. There you will find the Peer-to-Peer Control selection
- d. Click on it to open the Peer-to-Peer control screen.
- e. In that screen, you have three, tab selections
  - i. Peer Control Rules  
This screen allows you to create and modify rules
  - ii. Rules execution Status  
This screen allows you to see the activity the rules
  - iii. Pump Alternators  
This screen is where you create and modify alternators to rotate pump operations
- f. Select the Peer Control rules to create or modify a new rule
  - i. Click on the Add new pair of rules button is the upper left corner and a Create pair of rules dialog box will open. Fill in the selections and press the "Save Changes" button.
  - ii. If a rule already exists, they can be modified by pressing the Edit icon in the left column of the rule.
  - iii. Existing rules can be deleted by pressing the trash can icon.
- g. Select the Rule Execution Status to view the list of executed operations and their status
- h. Select the Pump Alternators tab to create, modify or delete alternators

# Crystal Ball Kit

## Comprehensive User Guide

### 2. Peer Control Rules setup

- When the value in the **Turn On Trigger Input**, the **Condition** selection and the **Compare Value** form a true statement, The **Turn On Output State** command is executed
- When the value in the **Turn OFF Trigger input**, the **condition** selection and the Compare Value form a true statement, The **Turn Off Output State** command is executed
- Dialog box Settings:

The screenshot shows a dialog box titled "Create Pair of Rules". At the top right, there is a "Save Changes" button and a close "X" button. The dialog is organized into several sections:

- Rule Settings:** Contains a "Name" input field and an "Enabled" checkbox which is checked.
- Input Settings:** Contains an "Input Type" dropdown menu. Below it are two columns: "Turn On Trigger" and "Turn Off Trigger". Each column contains "Station From", "Input", "Condition", and "Compare Value" fields.
- Output Settings:** Contains "Station To", "Pump Alternator Scheme", "Turn On Output State", "Output", "Stage", and "Turn Off Output State" fields.
- Notification Settings:** Contains "Callout Schedule" and "Retry Limit" fields.

### Rules Settings group

- Name:** Sets the name for the rule. This name will be visible in the rules list and the rule execution list and should easily identify the purpose of the rule
- Enable:** When this box is checked, the rule will be processed and the associated output will be controlled accordingly. When unchecked, the rule will be ignored and not processed.

#### Input Settings group

- Input Type:** Determines how the rule functions. Analog uses the scaled value of the input to control the selected output. Digital uses the On or Off state of an input to control the selected output.
- Multiple Inputs:**
  - This box can only be checked if the Input Type selected is digital.
  - When checked, this provides a separate, turn off trigger input. A second **Station From** and **Input** selection boxes will be available to configure. This is used when you have separate start and stop inputs.
  - When the conditions for the **Turn On Trigger** are true, which is when its Input value matches the **Compare Value**, the **Turn On Output State** command is sent.

# Crystal Ball Kit

## Comprehensive User Guide

4. When the conditions for the **Turn Off Trigger** are true, which is when it's **Input** value matches the **Compare Value**, the **Turn Off Output State** command is sent.
  5. When the **Turn On Trigger** and **Turn Off Trigger** are both false, then no changes occur to the selected output
  6. When the **Turn On Trigger** and **Turn Off Trigger** are both True, the **Turn Off Output State** takes precedence, and the command is sent
- v. It is recommended that when the digital input that is used for the digital input control, the **Notify When** is set to Never and the Callout Schedule is set to none. Otherwise, you will receive a callout notification every time an operational cycle occurs.

### Turn On Trigger sub-group

- vi. **Station From:** This is the station that the rule will be receiving data from.
- vii. **Input:** This is the input from the selected station above, that the rule will use to control by. If a name has been defined, it will display it, otherwise it will display the default name.
- viii. **Condition:**
1. If the Input Type is Analog, "Lesser Than" or "Greater than" can be selected.
  2. If the Input Type is Digital, it will always be "Equals".
- ix. **Compare Value:**
1. If the **Input Type** is Analog, a numeric value can be entered.
  2. If the **Input Type** is Digital, Either On or Off can be selected.

### Turn Off Trigger sub-group

- x. **Station From:** This is the station that the rule will be receiving data from when **Multiple Inputs** is enabled above.
- xi. **Input:** This is the input from the selected station above, that the rule will use to control by. It is only available if Multiple Inputs is selected above. If a name has been defined, it will display it, otherwise it will display the default name.
- xii. **Condition:**
- If the Input Type is Analog, "Lesser Than" or "Greater than" can be selected.
- If the Input Type is Digital, it will always be "Equals"

### xiii. Compare Value:

- If the **Input Type** is Analog, a numeric value can be entered.
- If the **Input Type** is Digital, Either On or Off can be selected and it will always be the opposite of the compare value in the **Turn On** trigger group.

### Output Settings group

In the **Output group**, if a **Station To** and **Output** is selected, the **Pump Alternator Scheme** and **Stage** will not be selectable. If an Alternator is desired, **Station To** and **Output** must first be set to none.

- xiv. **Station to:** This is the station that the rule will send the command to
- xv. **Output:** This is the output from the selected Station To above, that the rule will control. If a name has been defined, it will display it, otherwise it will display the default name.
- xvi. **Pump Alternator scheme:** This is the name of the alternator scheme to rotate the outputs
- xvii. **Stage:** This value will automatically be selected

# Crystal Ball Kit

## Comprehensive User Guide

### xviii. Turn On Output State:

1. **On:** An On command is sent to the unit. Local control for this output will be disabled
2. **Auto.** An Auto command is sent to the unit, this returns all outputs 1, 2, & 3 back to local, automatic control.

### xix. Turn Off Output State:

1. **Off:** An Off command is sent to the unit. Local control for this output will be disabled.
2. **Auto:** An Auto command is sent to the unit. This returns all outputs 1, 2, & 3 back to local, automatic control.

xx. **Callout Schedule:** This is the scheduled used if the command fails to receive a verification back from the unit within the retry limit set below

xxi. **Retry Limit:** The number of times the GuardDog server will attempt to send the command successfully before sending out the failure notification.

## 3. Alternator setup

- a. The alternator will take the place of the To Station and Output in the respective control rule
- b. Under the Pump Alternator tab,



Select the Pump Alternator Scheme to edit.

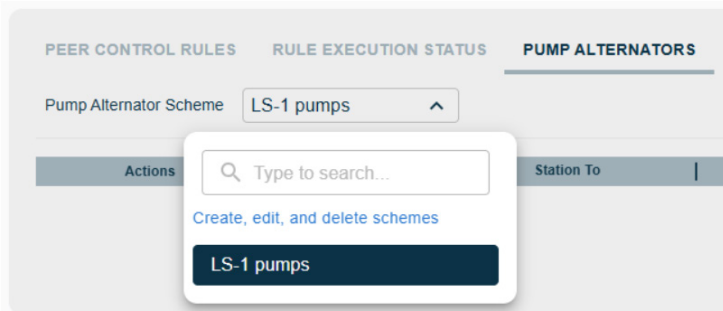

If no scheme exists or a new scheme needs to be created, click on the down arrow and select “Create, edit and delete schemes”

- c. Click on the “Add New Pump Alternator Scheme”
- d. Type in the name for the new Scheme. It should be descriptive of the system the scheme will be used for.
- e. Exit out of the Pump Alternator Schemes screen.
- f. Now select the new scheme that was created
- g. Click on the + Add New Pump Alternator button and the Create New Pump Alternator dialog box opens. You can add multiple alternator stages as needed.

# Crystal Ball Kit

## Comprehensive User Guide

**Create Pump Alternator** ? Save Changes X

Pump Alternator Scheme:  ⓘ

Station To:  ⓘ

Pump Service Status:  ⓘ

Stage:  ⓘ

Output:  ⓘ

- h. Select the scheme you wish to add a stage to
- i. The Stage number will be automatically created
- j. **Station To:** is the station that the alternator will send the command to
- k. **Output:** This is the output from the selected **Station To** above, that the alternator will control. If a name has been defined, it will display it, otherwise it will display the default name
- l. The actual command that will be sent is defined in the rule that referenced this alternator stage.
- m. **Pump Service Status:** Allow a pump to be taken out of service or temporarily disabled without deleting its alternator stage.

### 4. Examples

#### a. Water Tower control using two pressure switches with 1 well pump

This example shows the control rule for a water tower in a pump-up configuration, with start and stop pressures switches controlling a single well pump.

- i. In this example, only one rule needs to be created because only one pump is controlled.
- ii. This rule monitors the two inputs that are wired to the start and stop pressure switches. The switches may exist on a unit different than the unit that controls the well pump.
- iii. The start pressure switch is wired to open when the pressure falls below its setpoint.
- iv. The stop pressure switch is wired to close when the pressure rises above the stop setpoint.

**Create Pair of Rules** ? Save Changes X

**Rule Settings**

Name:  ⓘ Enabled:  ⓘ

**Input Settings**

Input Type:  ⓘ Multiple Inputs:  ⓘ

**Turn On Trigger**

Station From:  ⓘ

Input:  ⓘ

Condition:  ⓘ

Compare Value:  ⓘ

**Turn Off Trigger**

Station From:  ⓘ

Input:  ⓘ

Condition:  ⓘ

Compare Value:  ⓘ

**Output Settings**

Station To:  ⓘ

Pump Alternator Scheme:  ⓘ

Output:  ⓘ

Stage:  ⓘ

Turn On Output State:  ⓘ

Turn Off Output State:  ⓘ

Notification Settings

Callout Schedule:  ⓘ

Retry Limit:  ⓘ

#### b. Water tower control with three wells, using level transmitter and alternator.

This example shows the control rules for a water tower in a pump-up configuration with three well pumps and an analog level transmitter for control.

- i. With three control steps, three rules will need to be created
- ii. An alternator will be created to rotate which well pump will be the lead pump. The rotation occurs after the lead pump stops
- iii. It is recommended to create the alternator before creating the three rules
- iv. With this configuration, up to three pumps can be commanded on if the level falls low enough
- v. In this example, the three well pumps are all connected to the same unit while the level transmitter is on a different unit. The well pumps can be different units.

# Crystal Ball Kit

## Comprehensive User Guide

**Update Pair of Rules** Save Changes ×

**Rule Settings**

Name: Tower Control Stage 1 ? Enabled:  ?

**Input Settings**

Input Type: Analog Input ?

**Turn On Trigger**

Station From: Water Tower (418... ?  
Input: Tower Level ?  
Condition: Lesser Than ?  
Compare Value: 140 ft ?

**Turn Off Trigger**

Station From: Water Tower (418... ?  
Input: Tower Level ?  
Condition: Greater Than ?  
Compare Value: 150 ft ?

**Output Settings**

Station To: None ? Output: ?

Pump Alternator Scheme: Well Pump Altern... ? Stage: 1 ?

Turn On Output State: On ? Turn Off Output State: Off ?

**Notification Settings**

Callout Schedule: Plant Supervisors ? Retry Limit: 3 ?

**Update Pair of Rules** Save Changes ×

**Rule Settings**

Name: Tower Control Stage 2 ? Enabled:  ?

**Input Settings**

Input Type: Analog Input ?

**Turn On Trigger**

Station From: Water Tower (418... ?  
Input: Tower Level ?  
Condition: Lesser Than ?  
Compare Value: 135 ft ?

**Turn Off Trigger**

Station From: Water Tower (418... ?  
Input: Tower Level ?  
Condition: Greater Than ?  
Compare Value: 150 ft ?

**Output Settings**

Station To: None ? Output: ?

Pump Alternator Scheme: Well Pump Altern... ? Stage: 2 ?

Turn On Output State: On ? Turn Off Output State: Off ?

**Notification Settings**

Callout Schedule: Plant Supervisors ? Retry Limit: 3 ?

**Update Pair of Rules** Save Changes ×

**Rule Settings**

Name: Tower Control Stage 3 ? Enabled:  ?

**Input Settings**

Input Type: Analog Input ?

**Turn On Trigger**

Station From: Water Tower (418... ?  
Input: Tower Level ?  
Condition: Lesser Than ?  
Compare Value: 130 ft ?

**Turn Off Trigger**

Station From: Water Tower (418... ?  
Input: Tower Level ?  
Condition: Greater Than ?  
Compare Value: 150 ft ?

**Output Settings**

Station To: None ? Output: ?

Pump Alternator Scheme: Well Pump Altern... ? Stage: 3 ?

Turn On Output State: On ? Turn Off Output State: Off ?

**Notification Settings**

Callout Schedule: Plant Supervisors ? Retry Limit: 3 ?

# Crystal Ball Kit

## Comprehensive User Guide

		>	Tower Control Stage 1	Water Tower (41896)	Tower Level (Analog Input)	Lesser Than 140		On	Well Pump Alternator	1	Plant Supervisors	3	<input checked="" type="checkbox"/>	
			>	Tower Control Stage 1	Water Tower (41896)	Tower Level (Analog Input)	Greater Than 150		Off	Well Pump Alternator	1	Plant Supervisors	3	<input checked="" type="checkbox"/>
		>	Tower Control Stage 2	Water Tower (41896)	Tower Level (Analog Input)	Lesser Than 135		On	Well Pump Alternator	2	Plant Supervisors	3	<input checked="" type="checkbox"/>	
			>	Tower Control Stage 2	Water Tower (41896)	Tower Level (Analog Input)	Greater Than 150		Off	Well Pump Alternator	2	Plant Supervisors	3	<input checked="" type="checkbox"/>
		>	Tower Control Stage 3	Water Tower (41896)	Tower Level (Analog Input)	Lesser Than 130		On	Well Pump Alternator	3	Plant Supervisors	3	<input checked="" type="checkbox"/>	
			>	Tower Control Stage 3	Water Tower (41896)	Tower Level (Analog Input)	Greater Than 150		Off	Well Pump Alternator	3	Plant Supervisors	3	<input checked="" type="checkbox"/>

And a well pump alternator will also need to be created

### Peer-To-Peer Control

PEER CONTROL RULES    RULE EXECUTION STATUS    **PUMP ALTERNATORS**

Pump Alternator Scheme: Well Pump Altern... + Add New Pump Alternator

Actions	Stage	Station To	Output	Pump Service Status	Pump State	Move Stage
	1	Well Pump (41835)	Well Pump 1	In Service	Off	≡
	2	Well Pump (41835)	Well Pump 2	In Service	Off	≡
	3	Well Pump (41835)	Well Pump 3	In Service	Off	≡

### Update Pump Alternator

? Save Changes ×

Pump Alternator Scheme: Well Pump Altern... i      Stage: 1 i

Station To: Well Pump (41835) i      Output: Well Pump 1 i

Pump Service Status: In Service i

### Update Pump Alternator

? Save Changes ×

Pump Alternator Scheme: Well Pump Altern... i      Stage: 2 i

Station To: Well Pump (41835) i      Output: Well Pump 2 i

Pump Service Status: In Service i

### Update Pump Alternator

? Save Changes ×

Pump Alternator Scheme: Well Pump Altern... i      Stage: 3 i

Station To: Well Pump (41835) i      Output: Well Pump 3 i

Pump Service Status: In Service i

# Crystal Ball Kit

## Comprehensive User Guide

### Lift Station interlock

In this example, a lift station can be interlocked with another station to prevent one from running while the other station pumps are already running

- i. In this example, Lift Station #2 will be prevented from running if any Lift Station #1 pumps are running
- ii. The OmniSite units on both stations are configured for pump control.
- iii. Single input Digital type rules will be used
- iv. If either pump on LS#1 runs, both pumps on LS#2 will be turned off. When the pump on LS#1 stops, LS#2 pumps will be placed back into auto. This is accomplished by creating four rules. Two rules to turn off both pumps of LS#2 when Pump 1 of LS#1 runs and two more to turn off both pumps of LS#2 pumps when Pump 2 of LS#1 runs.
- v. Because the Turn On Output State only allows On and Auto to be selected, we must use the Turn Off Output State to turn off the respective outputs. This is accomplished by setting the Turn On Trigger Compare Value to OFF and the Turn Off Trigger Compare Value to On. This way, when the pump runs and the input is on, we issue an Off command to the remote pump.
- vi. This example only shows Lift Station #1 locking out Lift Station #2. If interlocking both ways are needed, an additional 4 rules would need to be created.

- 1st Rule - Lift Station#1 Pump 1 → Lift Station#2 Pump 1
- 2nd Rule - Lift Station#1 Pump 1 → Lift Station#2 Pump 2
- 3rd Rule - Lift Station#1 Pump 2 → Lift Station#2 Pump 1
- 4th Rule - Lift Station#1 Pump 2 → Lift Station#2 Pump 2

### Rule Overview

<input checked="" type="checkbox"/>	<input type="checkbox"/>	Tests output test	IQA_CR_04 (21463)	Input 3 (Digital Input)	Equals Off	IQA_CR_04 (21463)	Output 1	On	TEH_Test_Schedule	3	<input checked="" type="checkbox"/>
		Tests output test	IQA_CR_04 (21463)	Input 4 (Digital Input)	Equals On	IQA_CR_04 (21463)	Output 1	Off	TEH_Test_Schedule	3	<input checked="" type="checkbox"/>
<input checked="" type="checkbox"/>	<input type="checkbox"/>	LS#1 P1 to LS#2 P1	Lift Station #1 (41896)	Pump 1 Running (Digital Input)	Equals Off	Lift Station #2 (41835)	Pump 1	Auto	Plant Supervisors	3	<input checked="" type="checkbox"/>
		LS#1 P1 to LS#2 P1	Lift Station #1 (41896)	Pump 1 Running (Digital Input)	Equals On	Lift Station #2 (41835)	Pump 1	Off	Plant Supervisors	3	<input checked="" type="checkbox"/>
<input checked="" type="checkbox"/>	<input type="checkbox"/>	LS#1 P1 to LS#2 P2	Lift Station #1 (41896)	Pump 1 Running (Digital Input)	Equals Off	Lift Station #2 (41835)	Pump 2	Auto	Plant Supervisors	3	<input checked="" type="checkbox"/>
		LS#1 P1 to LS#2 P2	Lift Station #1 (41896)	Pump 1 Running (Digital Input)	Equals On	Lift Station #2 (41835)	Pump 2	Off	Plant Supervisors	3	<input checked="" type="checkbox"/>
<input checked="" type="checkbox"/>	<input type="checkbox"/>	LS#1 P2 to LS#2 P1	Lift Station #1 (41896)	Pump 2 Running (Digital Input)	Equals Off	Lift Station #2 (41835)	Pump 1	Auto	Plant Supervisors	3	<input checked="" type="checkbox"/>
		LS#1 P2 to LS#2 P1	Lift Station #1 (41896)	Pump 2 Running (Digital Input)	Equals On	Lift Station #2 (41835)	Pump 1	Off	Plant Supervisors	3	<input checked="" type="checkbox"/>
<input checked="" type="checkbox"/>	<input type="checkbox"/>	LS#1 P2 to LS#2 P2	Lift Station #1 (41896)	Pump 2 Running (Digital Input)	Equals Off	Lift Station #2 (41835)	Pump 2	Auto	Plant Supervisors	3	<input checked="" type="checkbox"/>
		LS#1 P2 to LS#2 P2	Lift Station #1 (41896)	Pump 2 Running (Digital Input)	Equals On	Lift Station #2 (41835)	Pump 2	Off	Plant Supervisors	3	<input checked="" type="checkbox"/>

### Lift Station #1, Pump 1 interlocking to Lift Station #2, Pump 1

Update Pair of Rules
Save Changes

---

**Rule Settings**

Name:  Enabled:

---

**Input Settings**

Input Type:  Multiple Inputs:

**Turn On Trigger**

Station From:

Input:

Condition:

Compare Value:

**Turn Off Trigger**

Station From:

Input:

Condition:

Compare Value:

---

**Output Settings**

Station To:

Pump Alternator Scheme:

Turn On Output State:

Notification Settings:

Output:

Stage:

Turn Off Output State:

Retry Limit:

# Crystal Ball Kit

## Comprehensive User Guide

### Lift Station #1, Pump 1 interlocking to Lift Station #2, Pump 2

Update Pair of Rules ? Save Changes ×

**Rule Settings**

Name:  ? Enabled:  ?

**Input Settings**

Input Type:  ? Multiple Inputs:  ?

**Turn On Trigger**

Station From:  ?  
Input:  ?  
Condition:  ?  
Compare Value:  ?

**Turn Off Trigger**

Station From:  ?  
Input:  ?  
Condition:  ?  
Compare Value:  ?

**Output Settings**

Station To:  ? Output:  ?  
Pump Alternator Scheme:  ? Stage:  ?  
Turn On Output State:  ? Turn Off Output State:  ?

**Notification Settings**

Callout Schedule:  ? Retry Limit:  ?

### Lift Station #1, Pump 2 interlocking to Lift Station #2, Pump 1

Update Pair of Rules ? Save Changes ×

**Rule Settings**

Name:  ? Enabled:  ?

**Input Settings**

Input Type:  ? Multiple Inputs:  ?

**Turn On Trigger**

Station From:  ?  
Input:  ?  
Condition:  ?  
Compare Value:  ?

**Turn Off Trigger**

Station From:  ?  
Input:  ?  
Condition:  ?  
Compare Value:  ?

**Output Settings**

Station To:  ? Output:  ?  
Pump Alternator Scheme:  ? Stage:  ?  
Turn On Output State:  ? Turn Off Output State:  ?

**Notification Settings**

Callout Schedule:  ? Retry Limit:  ?

### Lift Station #1, Pump 2 interlocking to Lift Station #2, Pump 2

Update Pair of Rules ? Save Changes ×

**Rule Settings**

Name:  ? Enabled:  ?

**Input Settings**

Input Type:  ? Multiple Inputs:  ?

**Turn On Trigger**

Station From:  ?  
Input:  ?  
Condition:  ?  
Compare Value:  ?

**Turn Off Trigger**

Station From:  ?  
Input:  ?  
Condition:  ?  
Compare Value:  ?

**Output Settings**

Station To:  ? Output:  ?  
Pump Alternator Scheme:  ? Stage:  ?  
Turn On Output State:  ? Turn Off Output State:  ?

**Notification Settings**

Callout Schedule:  ? Retry Limit:  ?

---

# REPORTS

---

# Crystal Ball Kit

## Comprehensive User Guide

### Account Manager

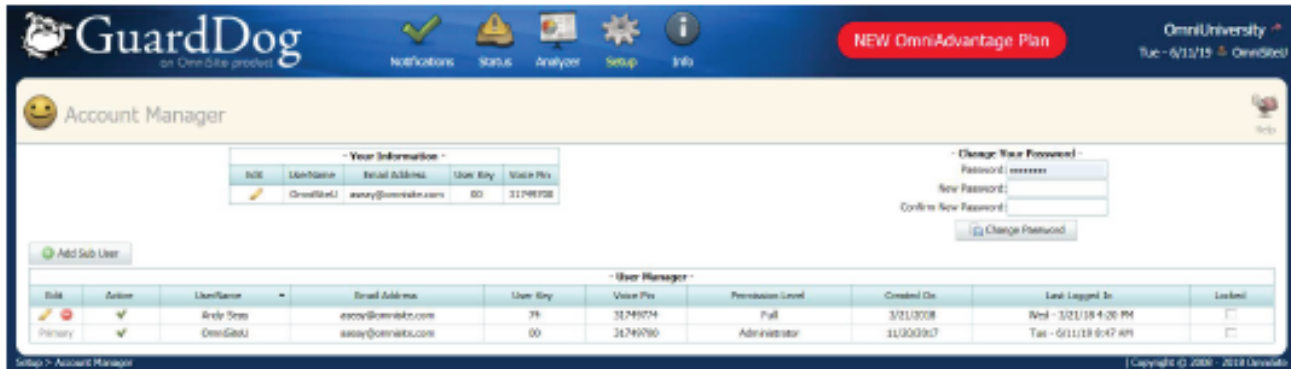

- Displays current user information
- Lists all users on the account with information about each entry
- Allows the user to change their password
- Allows Administrators to add new users and select permission levels
  - o Administrator has full access to all features and settings
  - o Full can edit settings and view all screens
  - o ReadOnly can view all screens in GuardDog, but cannot edit any settings

### Group Editor

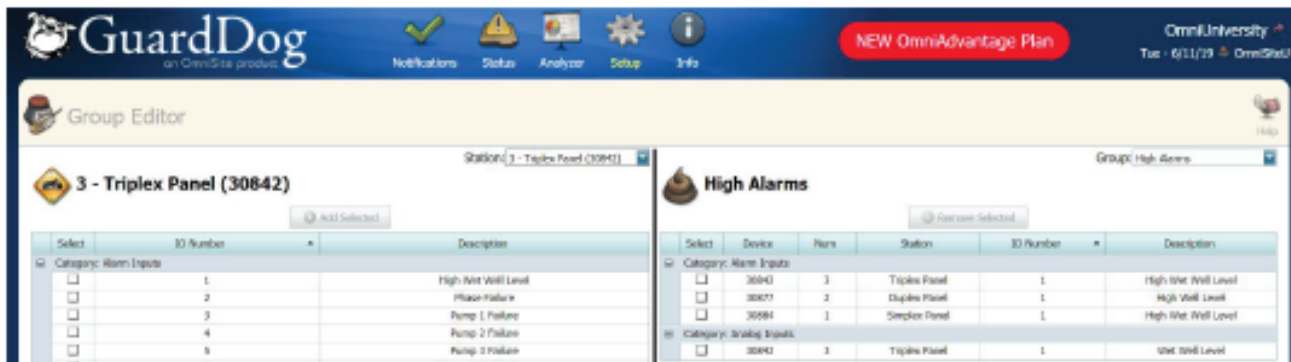

- Used to create and configure groups of inputs, which allows for customized views in the **Group Status** page, under the Status tab
- Inputs from multiple devices can be grouped together for easy viewing
- Default groups for Battery Status, Main Power, and Signal Strength already exist

# Crystal Ball Kit

## Comprehensive User Guide

### Notifications

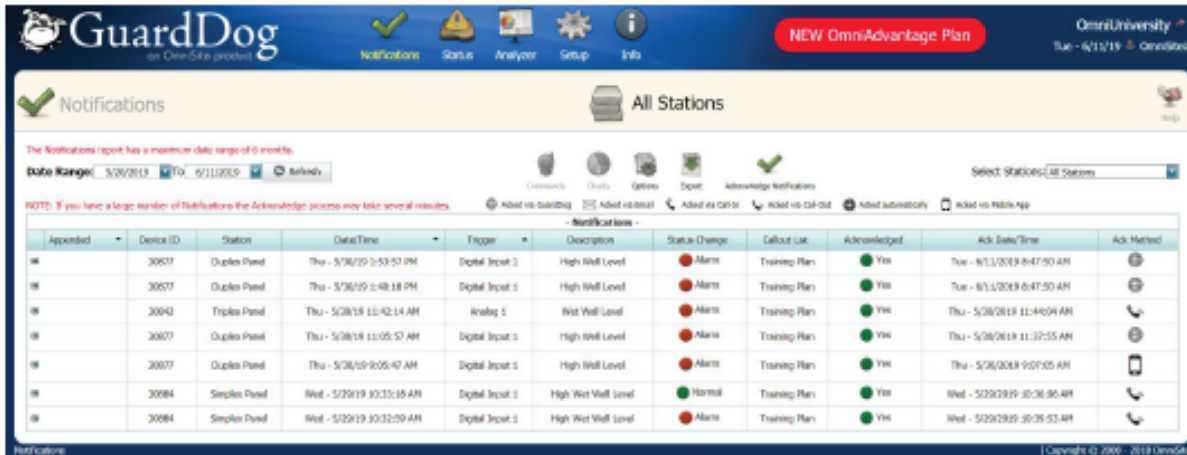

- Displays all notifications from a selected station or all stations during a selected date range (set on the top, left-hand side of the page)
- Allows user to acknowledge any displayed notifications
- Allows the currently displayed data to be exported in a variety of formats

### Status

#### Current Alarms

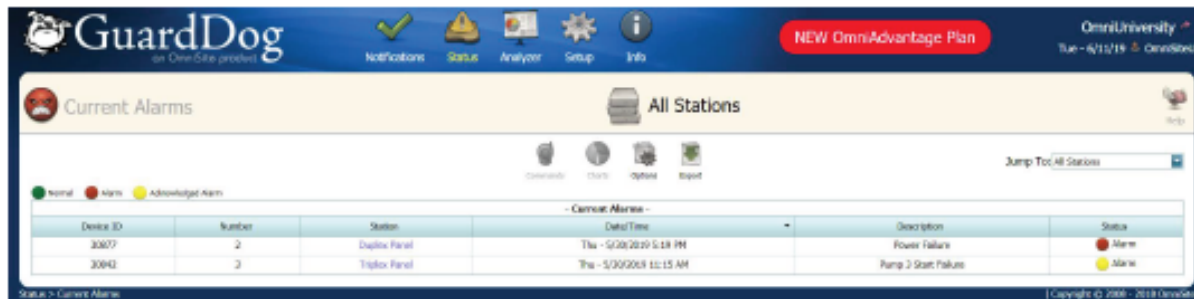

- Displays all current alarms for a station or all stations
- **Commands** button allows the user to request reports from the selected device

#### Quick Views

- Most pages here display similar information, arranged in different, easy-to-read formats

# Crystal Ball Kit

## Comprehensive User Guide

### Map View

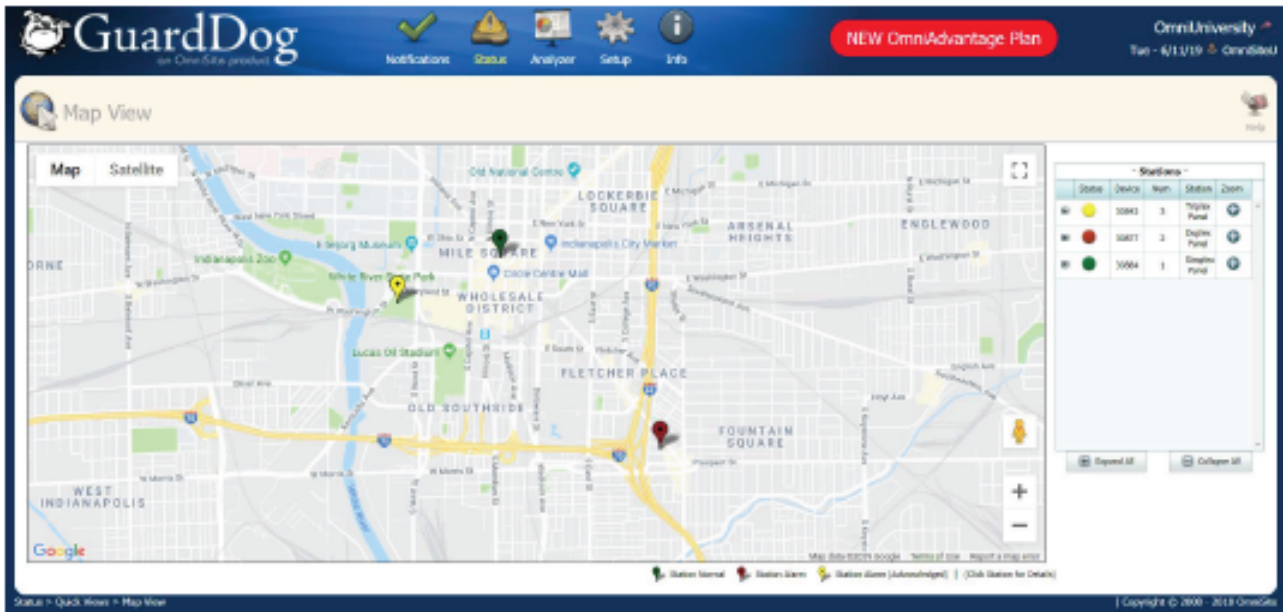

- Displays all stations (with a valid address) on an interactive map as pins
- Each pin is color coded in respect to the alarm status of that station
- Stations are also listed along the right side of the page
- Clicking on a pin will display additional information about that station

### Station Profiles



- Displays all stations graphically, with simple details about each station
- Stations can be rearranged using the **Options** button
- Each station has a link directly to its Device Status and Device Setup pages

# Crystal Ball Kit

## Comprehensive User Guide

### Station List

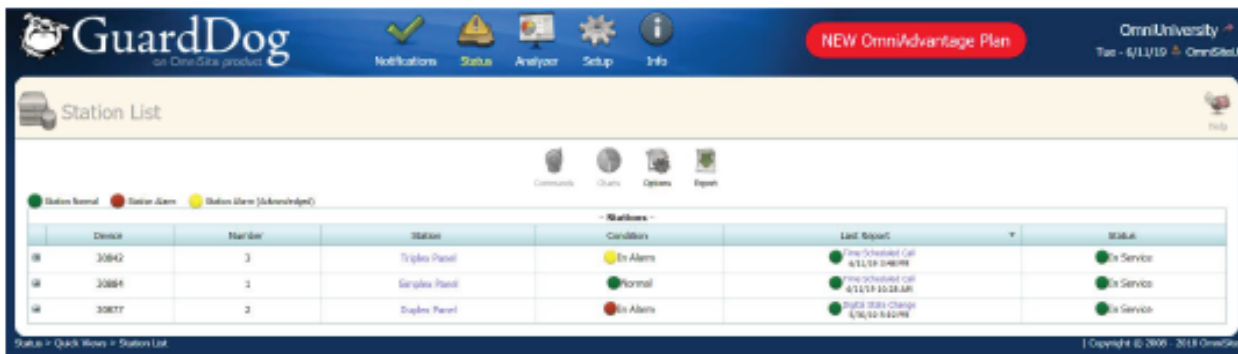

- Displays all stations in a list format with simple details about each station
- Each entry can be expanded with the plus button on the left side to display additional information
- Clicking the Station Name will take the user directly to the Device Status page for that station
- List can be exported in a variety of formats

### Device Status

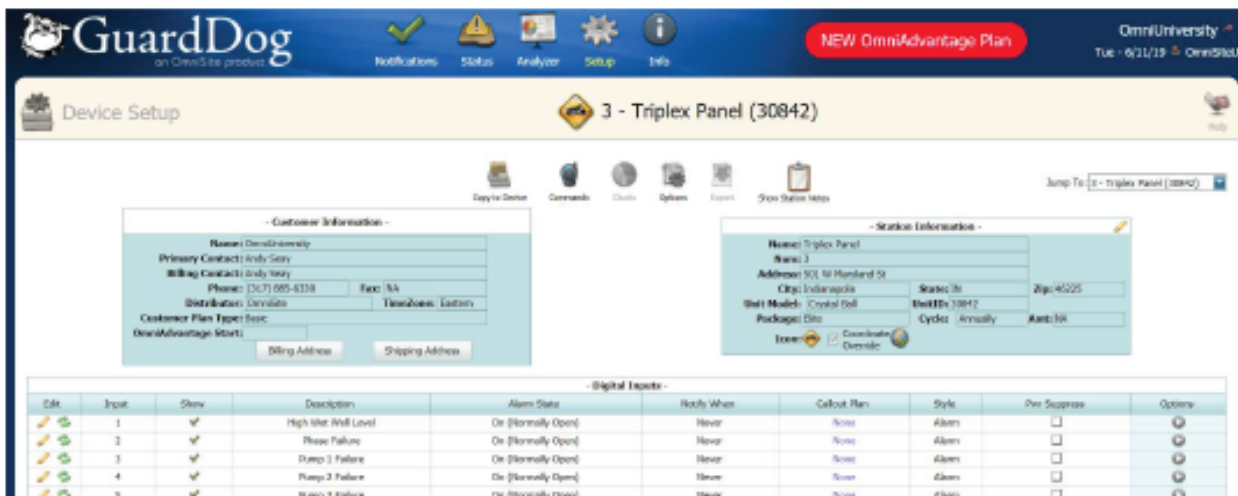

- Displays an in-depth summary of all inputs on a selected station
- Includes data about number of state changes and most recent state change for each input
- **Commands** button allows user to request reports or control the output relays on a Crystal Ball device through forward commands

# Crystal Ball Kit

## Comprehensive User Guide

### Group Status

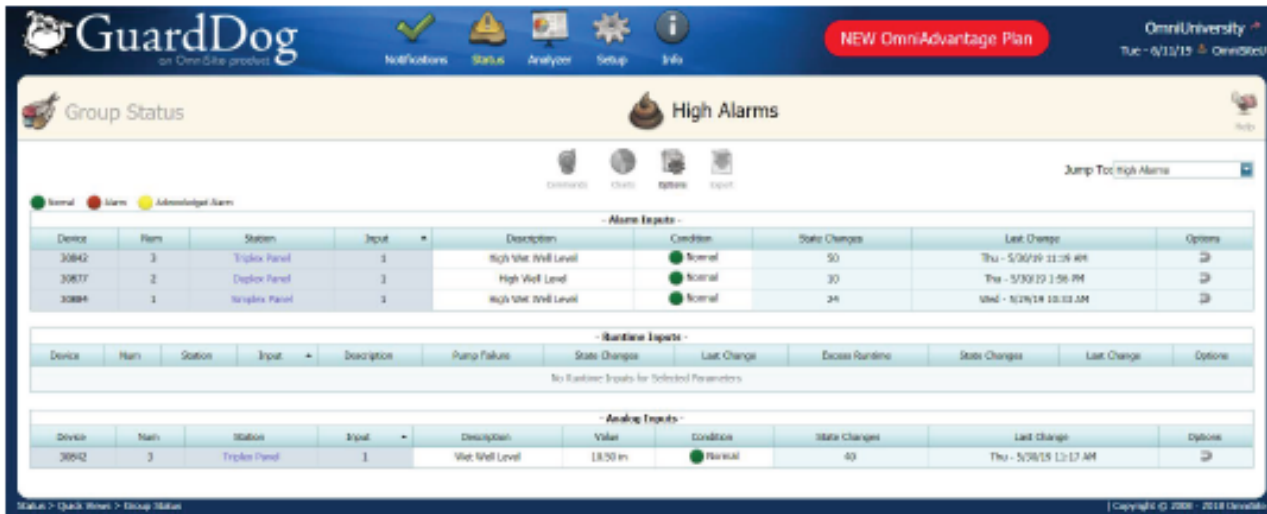

- Displays grouped inputs from multiple stations on a single screen
- Clicking a Station Name will take the user directly to the Device Status page

### Device Snapshot



- Displays a quick overview of one or all stations, including data from all inputs
- **Charts** button allows user to view a graph of signal strength readings

### Logs

- Device Activity, Status History, and Alarm History all display data from a selectable date range
  - o **Device activity:** displays a list of all events (pump calculations, time scheduled reports, input state changes) and where they were posted

# Crystal Ball Kit

## Comprehensive User Guide

- **Status History:** displays a graphical log of input changes, hardware configurations, and responses to forward commands
- **Alarm History:** displays the history of alarms for each input on a station, including start and stop times, with duration and totalization

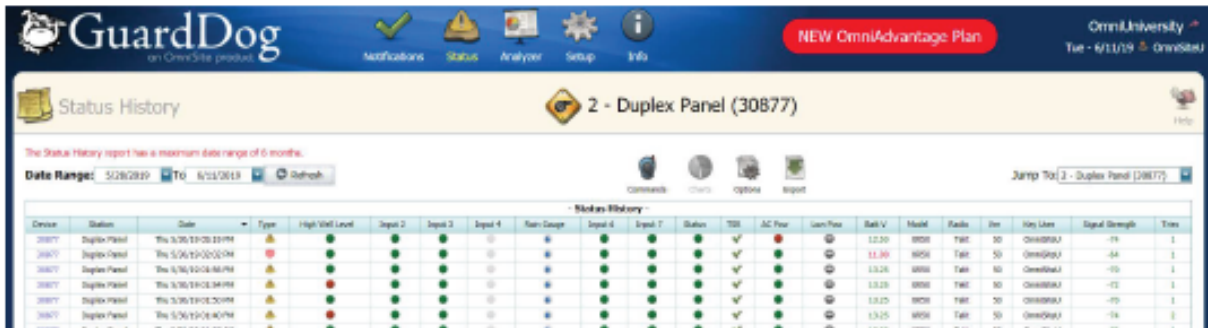

- **Station Notes** displays notes for one or all stations and allows editing and exporting of notes

## Analyzer

- These sections display data collected by devices and allow data to be displayed in graphs

## Pump Calculations

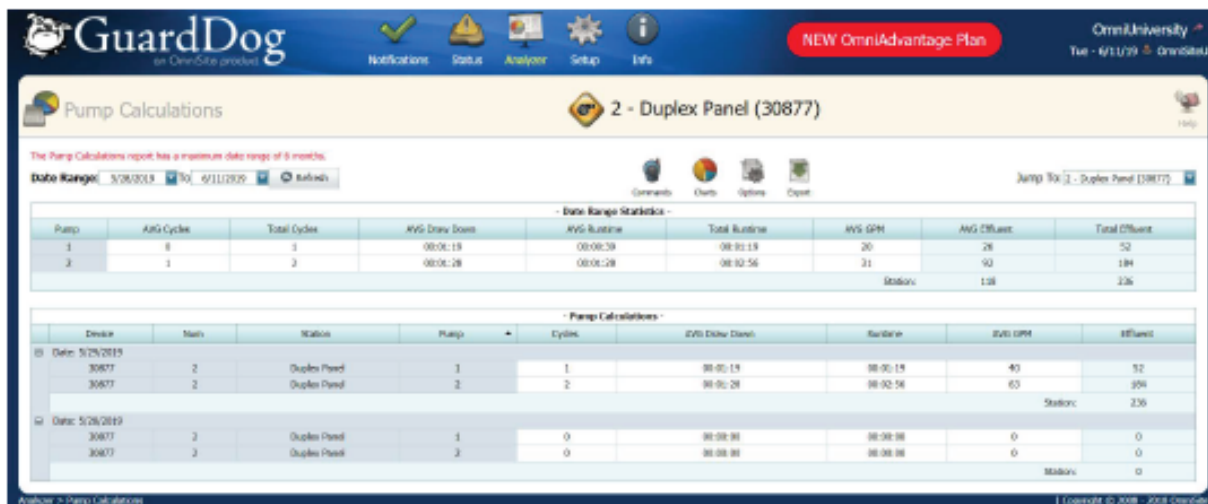

- Displays ON/OFF cycles, runtime hours, GPM, drawdown, and station effluent
- Data is displayed for a selectable date range, with totaled figures at the top and day-by-day breakdowns listed below

# Crystal Ball Kit

## Comprehensive User Guide

### Influent

- Displays influent for each station over a selectable date range, broken down into two-hour increments for each day
- Allows a comparison between influent and rainfall data, if both are collected

**Tip:** Comparing influent to rainfall is a good way to help analyze sources of infiltration into a wastewater system.

### Rainfall

- Displays rainfall data for each station over a selectable date range, broken down into two-hour increments for each day
- Allows daily totals to be viewed

### Counters

- Displays data for up to two counters per station, including totalization

### Analog Readings

- Displays 4-20mA readings for up to 4 analog inputs on a selectable device
- Input readings are scaled based on the values set on Device Setup page

## Info

### Help

- **Guides:** Provide a full walkthrough of all features of GuardDog, including details about all functions and how to properly utilize them
- **Frequently Asked Questions:** List of FAQs with answers
- **Video Library:** Introduction and Installation videos

### Contact Us

- Contact details for OmniSite or the user's sales representative

### Warranty

- Displays warranty information for all devices on current account
- Provides access to downloads for service contract and warranty documents

### Service Agreement

- Displays the service agreement for using GuardDog

---

# TROUBLESHOOTING

---

# Crystal Ball Kit

## Comprehensive User Guide

### 6.0 TROUBLESHOOTING

#### 6.1 Troublshooting guide

PROBLEM	PROBABLE CAUSE	RECOMMENDED ACTION
Unit does not transmit alarms, and no control panel lights are illuminated	<b>No Power</b>	<ul style="list-style-type: none"> <li>• Check 120 VAC or 12 VDC power source</li> </ul>
Unit does not transmit alarms, and the power source is present	<b>Cellular Signal reception is not suitable</b>	<ul style="list-style-type: none"> <li>• Inspect the cellular signal strength LED on the face of the unit. If it is NOT GREEN, you MAY have a weak signal</li> <li>• Call OmniSite at 317-885-6330</li> <li>• We will observe the transmitted signal strength and suggest options for you - which many include replacing or relocating the antenna</li> </ul>
My field alarm contacts open and close, but the OmniSite unit does not appear to be doing anything	<b>Wiring problems or contacts have not remained open or closed for at least 5</b>	<ul style="list-style-type: none"> <li>• The OmniSite RTU will transmit an alarm signal if it changes “state: and remains in that “state” for at least 5 seconds</li> <li>• NOTE: This is a user adjustable time delay. It may be longer for your application.</li> <li>• Disconnect the field wires from the RTU for the alarm input in question.</li> <li>• Using a volt-ohm meter determine that your contacts are actually opening and closing. If not, make a field repair.</li> <li>• If they are, check on the Crystal Ball front panel to see that the associated LED goes on/off as your field signal changes.</li> <li>• Lastly, visit Guarddog.OmniSite.com to confirm that you have an associated alarm trigger and callout list specified for the event.</li> </ul>
My pump runtime readings are not automatically updating in GuardDog	<b>Time Scheduled reports are not enabled</b>	<ul style="list-style-type: none"> <li>• The OmniSite RTU reports pump runtimes and other values on time scheduled intervals (typically once/day).</li> <li>• Manually “enable” this feature on GuardDog.</li> </ul>

# Crystal Ball Kit

## Comprehensive User Guide

PROBLEM	PROBABLE CAUSE	RECOMMENDED ACTION
cont.	cont.	<ul style="list-style-type: none"> <li>You can additionally manually request the pump runtime values by issuing the appropriate command in GuardDog.</li> </ul>
<p>The OmniSite unit keeps calling me with alarms; when I visit the site, I cannot find any problems</p>	<p><b>OmniSite RTU is receiving “false” alarms</b></p>	<ul style="list-style-type: none"> <li>Your OmniSite RTU is a sophisticated piece of electronic monitoring equipment. It is only as good as the equipment it is monitoring. If your control panel is issuing false alarms, the OmniSite RTU WILL REPORT THEM.</li> <li>Contact your local OmniSite distributor to locate causes for false alarms from your equipment.</li> <li>Increase alarms time delays to eliminate false alarms</li> </ul>
<p>Analog Inputs not working</p>	<p><b>Wiring Error</b></p> <p><b>Incorrect Software Scaling</b></p>	<ul style="list-style-type: none"> <li>First check to see that your analog device is wired EXACTLY as shown in this manual. Correct faulty wiring, or if okay, see below.</li> <li>Connect a milliamp meter to the 4-20mA loop in question and confirm correct 4-20mA signal.</li> <li>If okay, use the local display/keypad to see that the 4-20mA input is correctly “scaled” and alarm set point applied</li> </ul>
<p>Relay Outputs not working</p>	<p><b>Wiring Error</b></p> <p><b>Incorrect Software Setpoint</b></p>	<ul style="list-style-type: none"> <li>First check to see that your analog device is wired EXACTLY as shown in this manual. Wiring a relay contact into a field hand-off switch takes experience. If you are not sure, seek a qualified electrician. If okay, see below.</li> <li>Check your relay (pump) on/off set points have been correctly entered using the local display/keypad.</li> </ul>

# Crystal Ball Kit

## Comprehensive User Guide

PROBLEM	PROBABLE CAUSE	RECOMMENDED ACTION
cont.	<p><b>Incorrect Software Setpoint cont.</b></p> <p><b>Relay in Manual Control</b></p>	<ul style="list-style-type: none"> <li>• Next, check that the pumps(s) are not removed from the software rotation.</li> <li>• Verify that the correct sensor is being used (floats or analog) in set up</li> <li>• Lastly, verify that the software control is in automatic and NOT manual control</li> </ul>

Have questions? Contact OmniSite Technical Support at

**317-885-6330 x3**

or online at

**[www.omnisite.com](http://www.omnisite.com)**

# Crystal Ball Kit

## Comprehensive User Guide

### 6.2 Setting up the Voltmeter - To Check Signals you'll need a Volt-Ohm Meter!

The first step is to properly adjust your voltmeter (Figure 1). A voltmeter is shown below. Things to verify is that the voltmeter is set to measure AC voltages and that the terminal leads are in the correct position. The voltmeter will outline where the terminal leads need to be on the device.

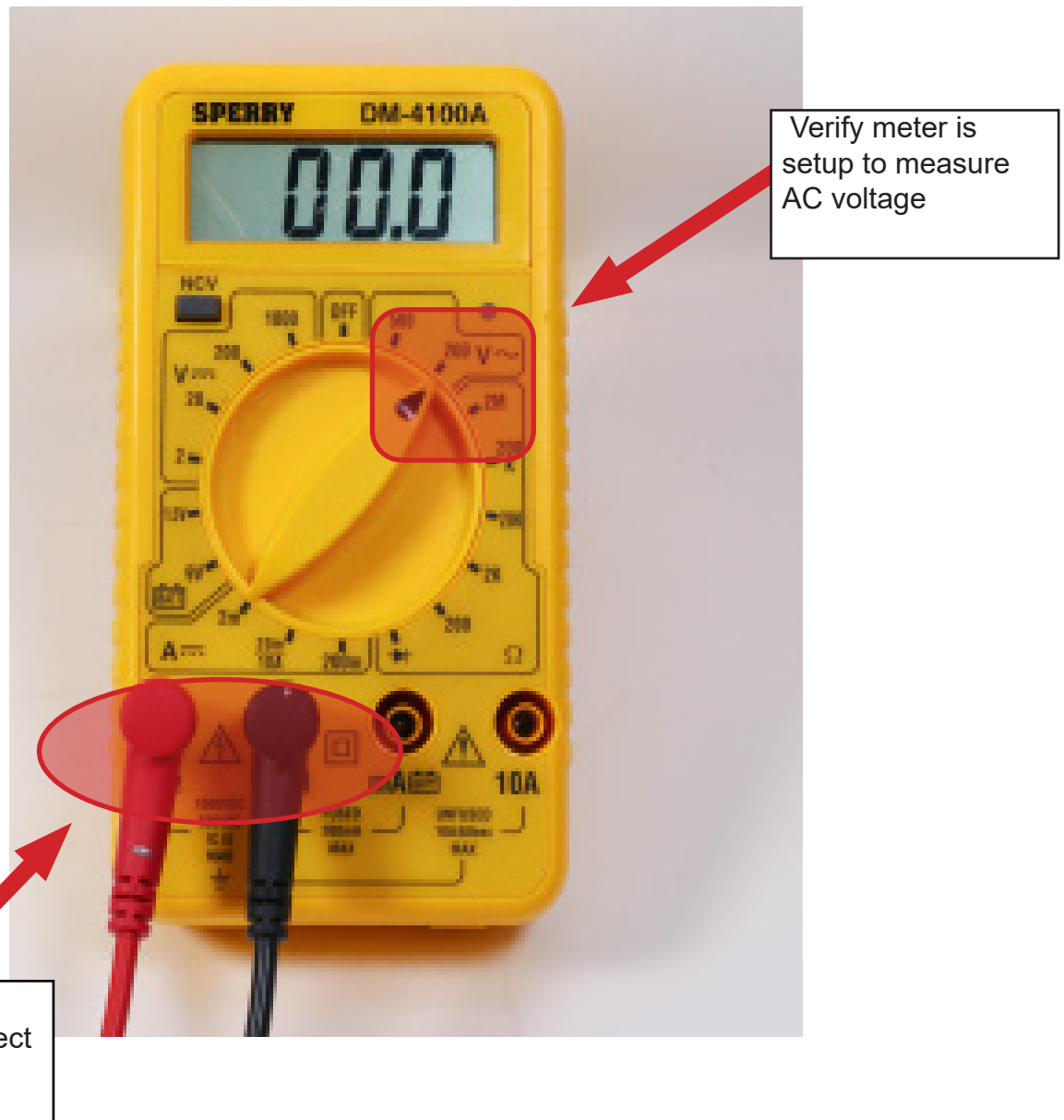

# Crystal Ball Kit

## Comprehensive User Guide

### Measuring AC Voltages

You can now use the two terminal leads to measure AC voltages powering your OmniSite Crystal Ball (Figure 2). Use the chart below and verify you are measuring these voltages. If you are not reading these voltages from an AC circuit, there may be an electrical issue inside the panel that should be addressed immediately.

Terminal Positions	Voltage measured
Hot & Neutral	120 VAC
Hot & ground	120 VAC
Neutral & Ground	0 VAC

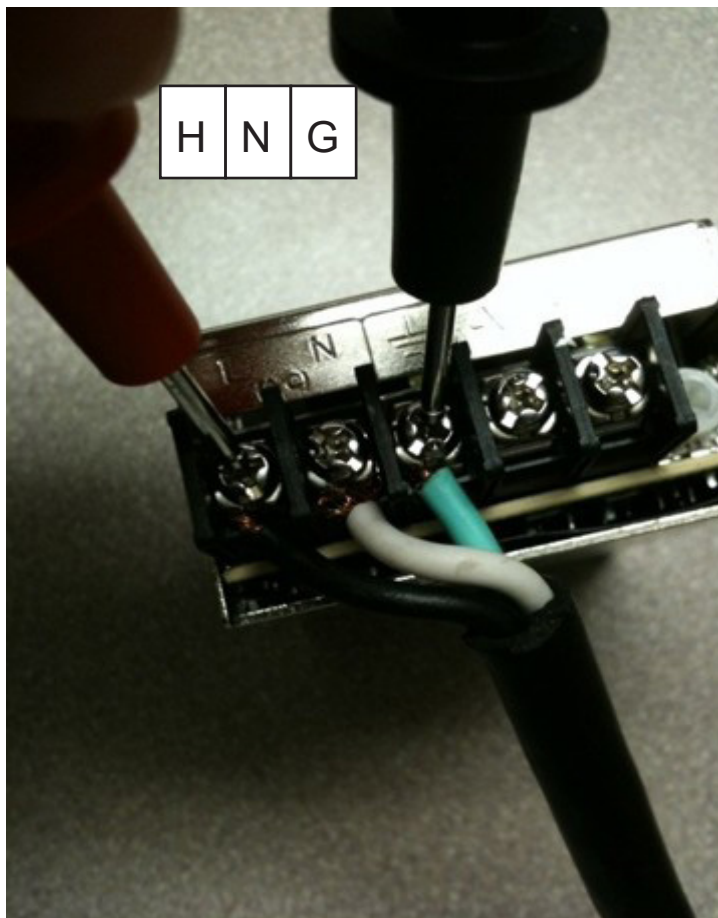

Red Terminal Lead

Black Terminal Lead

# Crystal Ball Kit

## Comprehensive User Guide

### DC Voltages

VDC stands for Volts Direct Current and is different than measuring AC voltage, as there is a (+) VDC and a (-) VDC. Later in this manual, we will cover how to wire Non-Powered contacts. Most Non-Powered contacts utilize Crystal ball onboard power supply. This power supply outputs around 13 volts DC (VDC) to the contact. Understanding DC voltages is important in understanding how to wire Non-Powered contacts using the onboard power supply.

### Setting up the Voltmeter

The first step is to properly adjust your voltmeter (Figure 3). A voltmeter is shown below. Things to verify is that the voltmeter is set to measure DC voltages and that the terminal leads are in the correct position. The voltmeter will outline where the terminal leads need to be on the device.

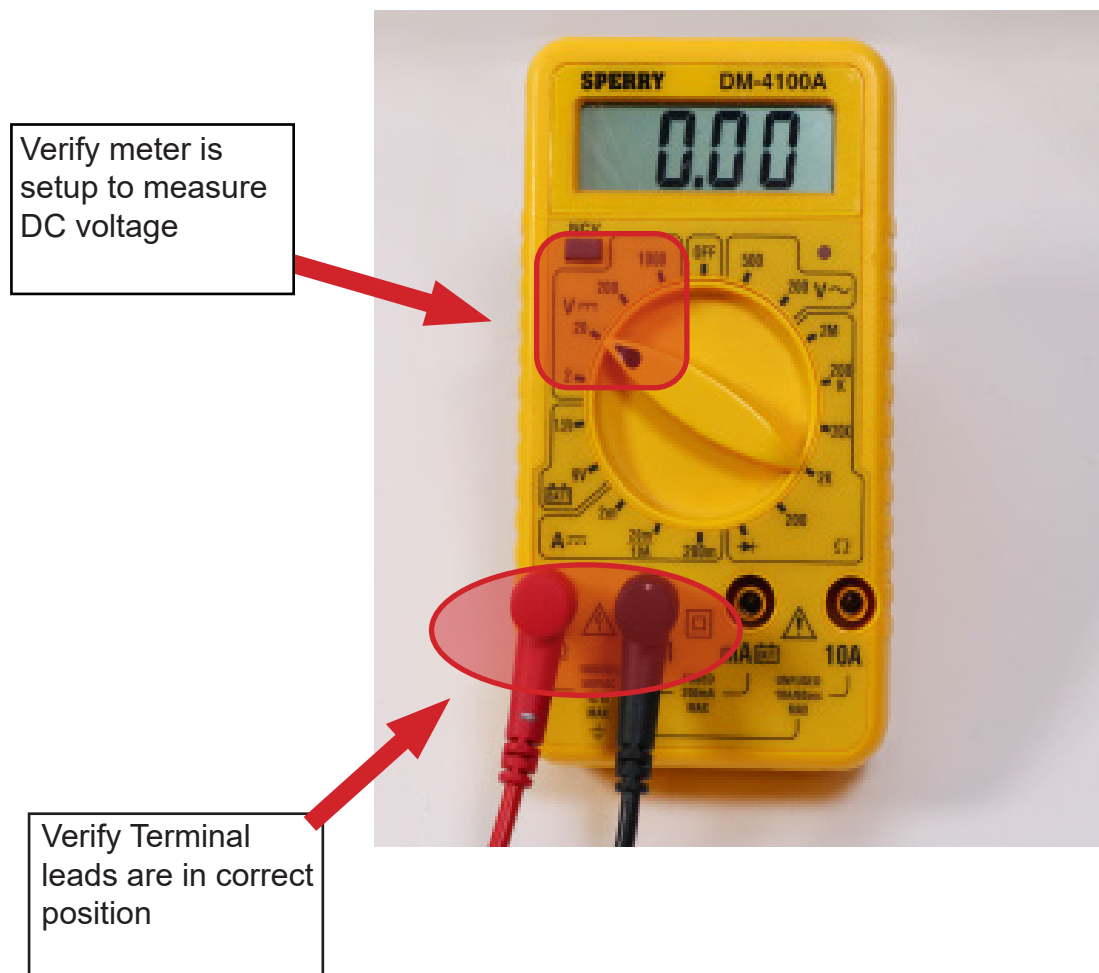

# Crystal Ball Kit

## Comprehensive User Guide

### Measuring DC Voltages

You can now use the two terminal leads to measure DC voltages (Figure 4 & 5). Anytime you measure a DC voltage, you should get a positive (+) reading from the meter, when using the red lead for the (+) terminal, and black lead for the (-) terminal. If these terminals are reversed, the meter will read a negative (-) DC voltage.

#### POSTIVE DC READING

Example shown- Testing the Crystal Ball back-up battery voltage. Your battery should read more than 12 volts DC

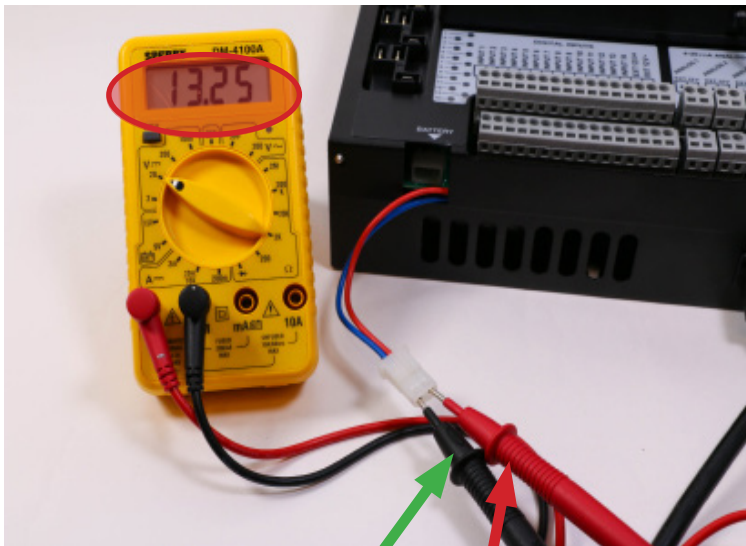

V-      V+

Red-Red, Black-Black terminal leads.  
Will receive a (+) VDC reading.

#### NEGATIVE DC READING

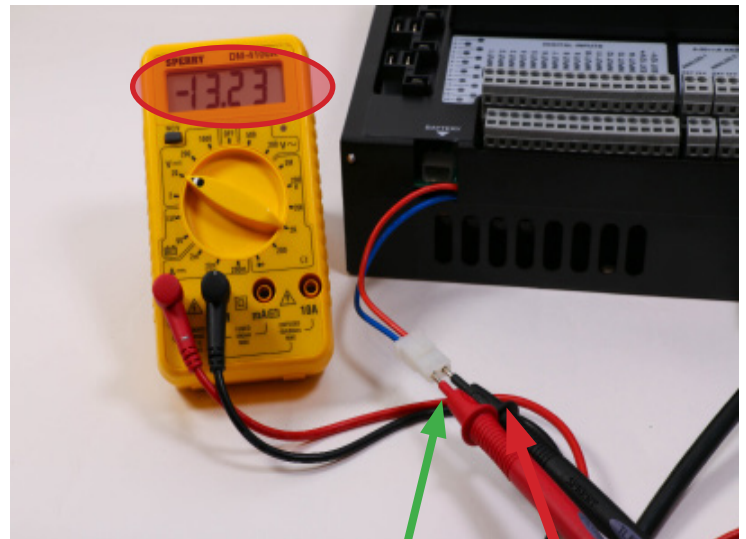

V-      V+

Terminal Leads, polarities reversed.  
Will receive a (-) VDC reading.

# Crystal Ball Kit

## Comprehensive User Guide

### DIGITAL INPUTS- REFERENCE SECTION

#### UNPOWERED, DRY CONTACTS

Wiring to any NON-POWERED CONTACT- in this example, input 1 is used. The Crystal Ball CANNOT monitor a dry, unpowered contact unless it is wired as shown below.

Crystal Ball Terminal Blocks

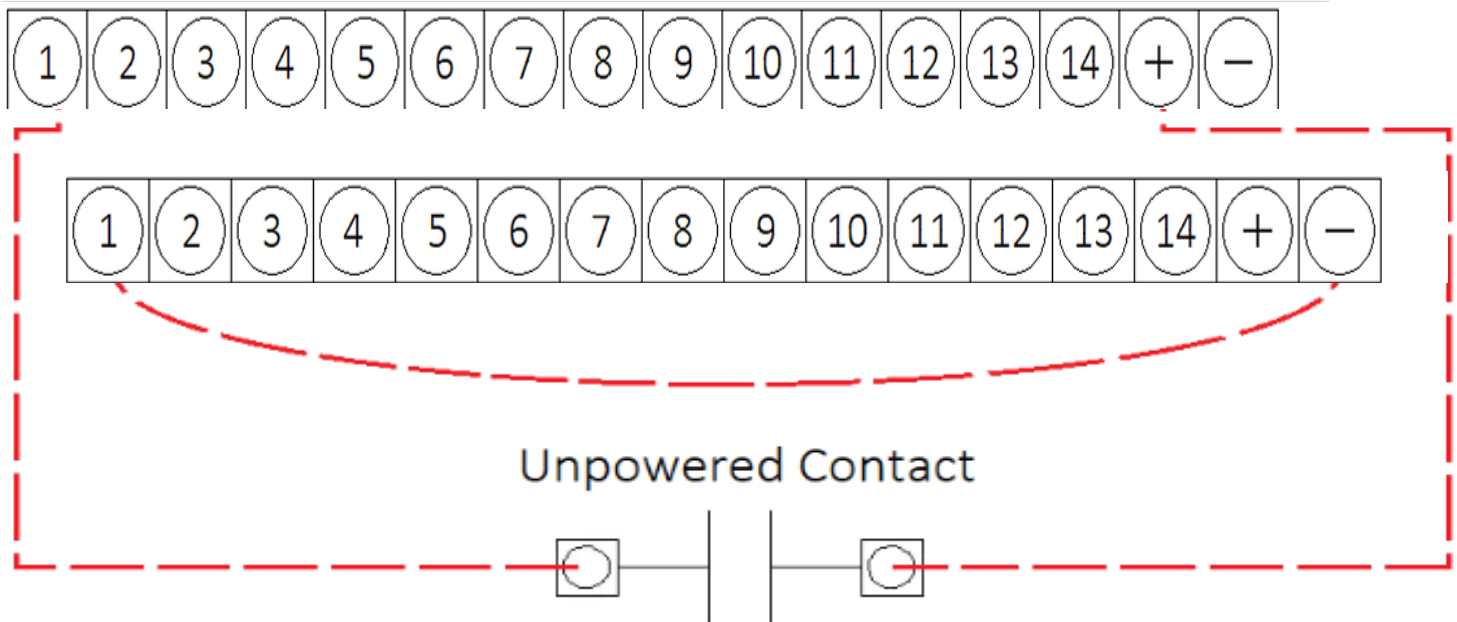

# Crystal Ball Kit

## Comprehensive User Guide

### OMNISITE CURRENT SWITCH WIRING

The OmniSite Current Switch can be used to accurately monitor the ON/OFF cycles of a pump. The current switch is a simple solution for accumulating Pump Calculations. Note the current switch is NOT our 4-20mA amp probe

The wiring diagram for the device is shown below. Please keep in mind this is using an XR50 terminal block. For the XR50, inputs 8, 9, and 10 are used for pump runtimes, while with the Crystal Ball, inputs 12, 13, and 14 are used.

\*Simply pass any HOT leg of your pump through the current switch.



\*Then, wire as shown below:

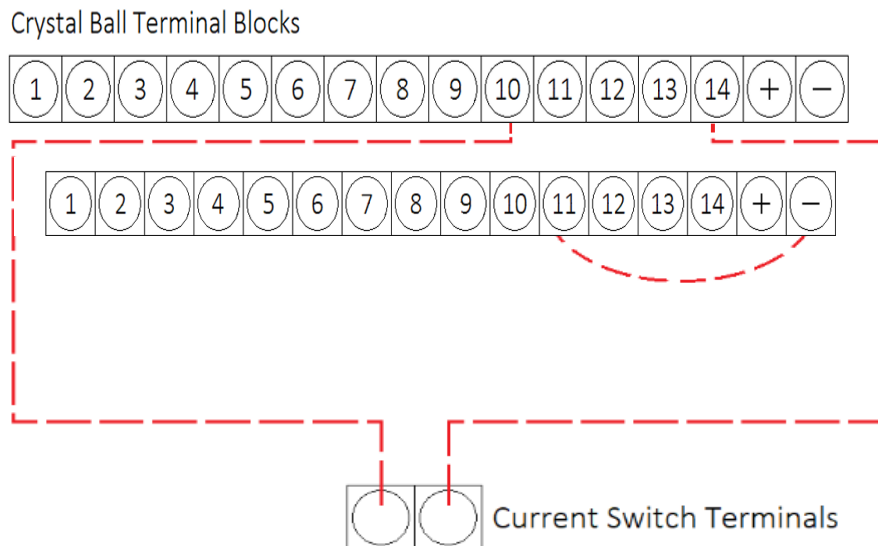

# Crystal Ball Kit

## Comprehensive User Guide

### POWERED CONTACTS

Wiring to any POWERED DEVICES – in this example, input 1 is used.

For the control circuit, the following notation is used:

X1 = HOT, 120 VAC

X2= NEUTRAL, 120 VAC

#### Crystal Ball Terminal Blocks

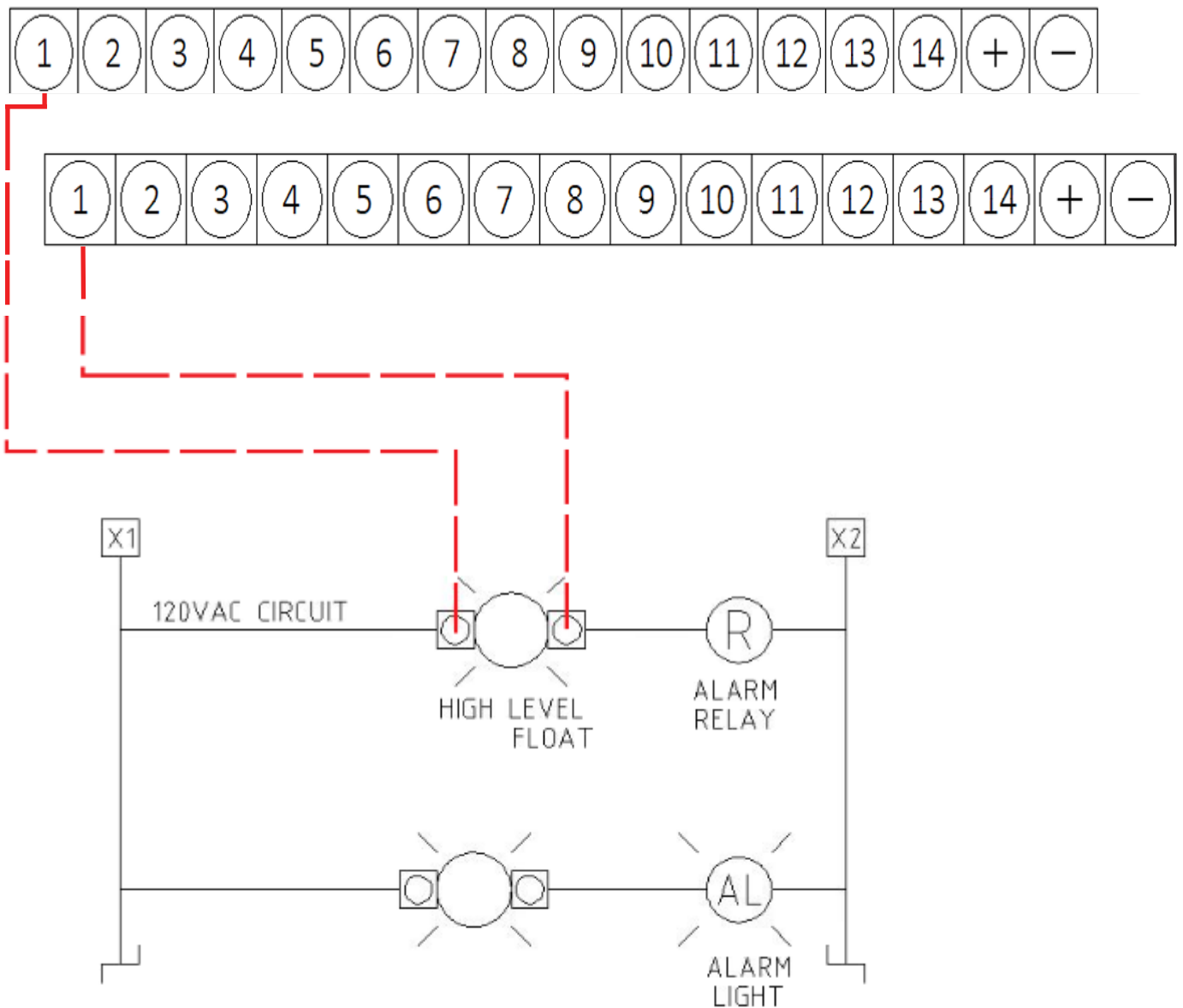

# Crystal Ball Kit

## Comprehensive User Guide

### RAIN COLLECTOR

Below explains the steps for setting up a Rain Collector  
(Part Number: S-MI-RGAUGE).

#### Setup

1. Before using the rain collector, cut and remove cable tie from tipping bucket located inside rain cone.
2. Cut off the end of the 4-pin modular connector on the modular “phone” cable.
3. Strip the black modular cable back about 4-5 inches and then strip the black, red, green, and yellow cables back about 1 inch.
4. Land the black and red wires into input #5 on the top digital input terminal block.
5. Land the yellow and green wires into the “+” on the top digital input terminal block.
6. Land a jumper wire from input #5 to the “-“on the bottom digital input block.

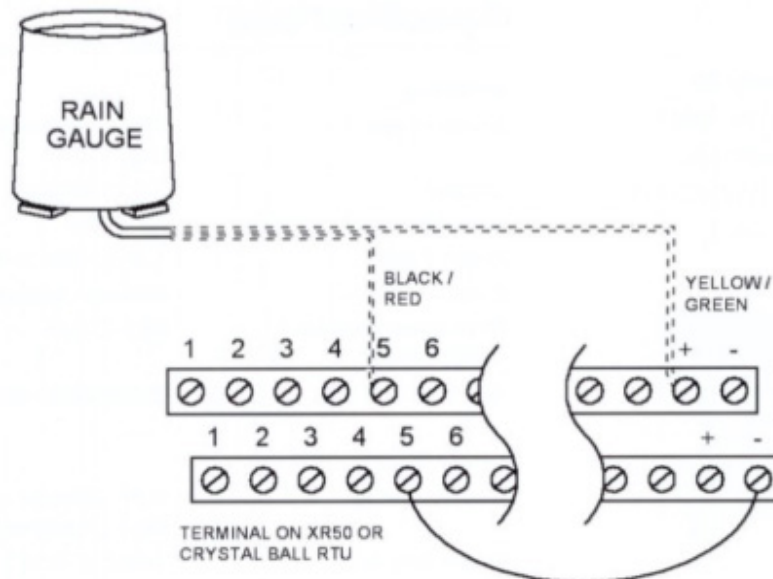

DO NOT FORGET TO SETUP THE SETTINGS IN THE UNIT:

7. You will need to select ENTER SETUP>SETUP DIG INPUTS and then go to INP 5. Next, press ENTER and change the selection to RAIN.
8. To check to see if you have properly hooked up the rain collector, simply flip the teeter totter collector to see if Input #5 LED toggles on & off. You will also want to enable the OmniSite RTU and then go to VIEW INPUTS, scroll down to RAIN PULSES, and verify the totalized rain value is counting up. The Crystal Ball will only accumulate pulses from rain gauges where each pulse = 0.01” of rain

# Crystal Ball Kit

## Comprehensive User Guide

### COUNTER SETUP

Below explains the steps for setting up a Counter with an OmniSite RTU. Counters can be configured on inputs 6 and/or 7 of the XR50 or Crystal Ball. Counters require wiring and settings.

First, the counting device must be wired as detailed below:

Crystal Ball Terminal Blocks

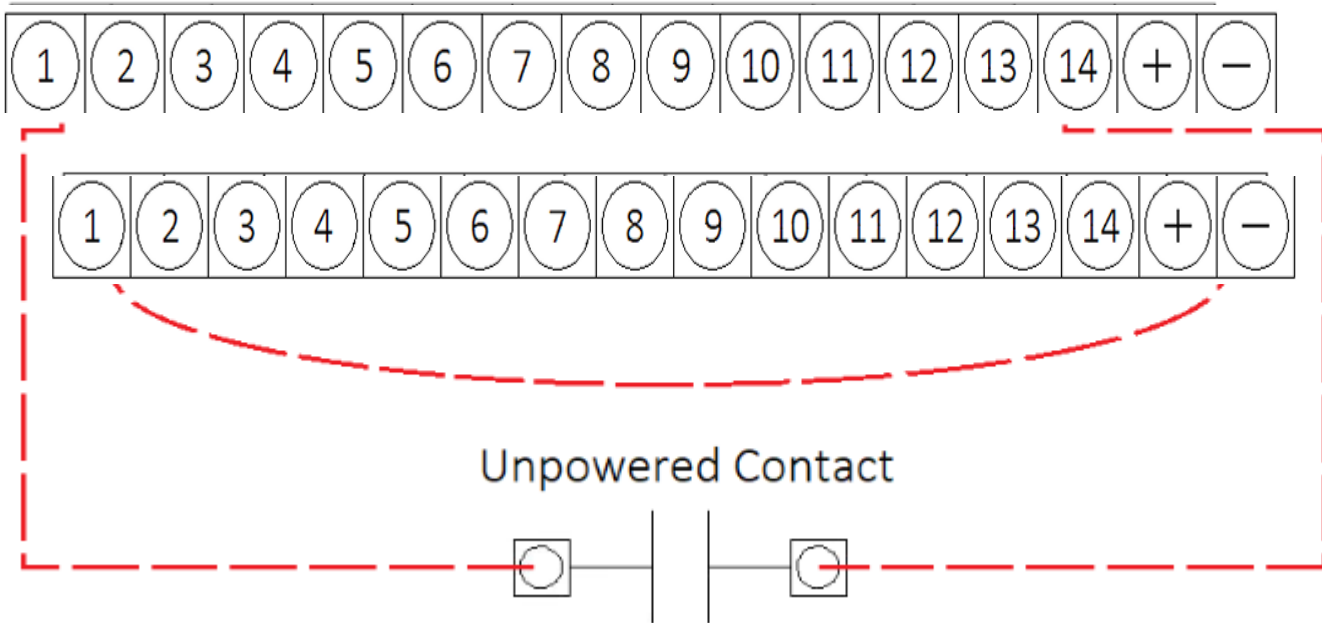

### Unit Settings Configuration:

1. You will need to select ENTER SETUP>SETUP DIG INPUTS and then go to INP 6/7. Next, press ENTER and change the selection to COUNT.
2. To check to see if you have properly hooked up the counter, force the counting device to show a change and see if Input #6/7 LED toggles on & off. You will also want to enable the OmniSite RTU and then go to VIEW INPUTS, scroll down to COUNTER1/COUNTER2, and verify the totalized pulse count value is incrementing.

---

# USING CRYSTAL BALL AS PUMP CONTROLLER

---

# Crystal Ball Kit

## Comprehensive User Guide

### 7.0 Using the Crystal Ball as your Primary or BackUp Pump Controller

---

The Crystal Ball is a combination pump controller and telemetry device. This means you monitor sensor data and alarms from your control panel, and you can also automatically control your pumps via well level readings connected to your Crystal Ball.

The following pages describe how you can use the Crystal ball in many different pump-up or pump-down configurations. It supports control via floats, 4-20mA transmitter, and 4-20mA transmitter with a convenient (2) float back-up control.

It also has built in alternation, pump failure alarms, inter-start pump time delays, remove-from-alternation settings, grease control algorithm to automatically randomize your on/off setpoints from a 4-20mA transmitter to prevent the pump(s) from starting and stopping at the same elevations each time, and thus extends the time it takes the well to build-up grease rings. This gives you more time between vac-truck trips to clean the grease out of the lift station.

**NOTICE – All products fail. This includes the Omnisite Crystal Ball. You can use the Crystal Ball as a primary or back-up pump controller, however, if the Crystal Ball is your primary controller, then OMNISITE STRONGLY RECOMMENDS you have a separate backup controller that takes over, automatically, if our product would fail.**

**Conversely, if you have another brand of primary pump controller, OMNISITE STRONGLY RECOMMENDS that you make the Crystal Ball your backup pump controller. It will automatically take over if your primary pump control fails. This ensures redundancy in your operations to prevent unnecessary sewage spills. This manual section explains how to use the Crystal Ball as a primary or backup pump controller**

You can do all this by landing your wires on the correct terminals on the Crystal Ball, and using simple selection menus on the face of the Crystal Ball display, configuring your device using up, down, enter, exit keys. There is no complex PLC programming required like you would find in your typical SCADA system. Omnisite is the future of SCADA, eliminating complex and time consuming programming

# Crystal Ball Kit

## Comprehensive User Guide

Refer to the below diagram which shows where to connect your wires, if you are using the Crystal Ball as a primary pump controller. If you are unable to read or follow this diagram **STOP NOW**. This means you don't have the experience to read schematic diagrams, and you should hire an experienced installer to install this product. Omnisite has authorized representatives across the USA, and we also offer free training at our factory in Indianapolis. For either of these options, contact us by email at [sales@omnisite.com](mailto:sales@omnisite.com)

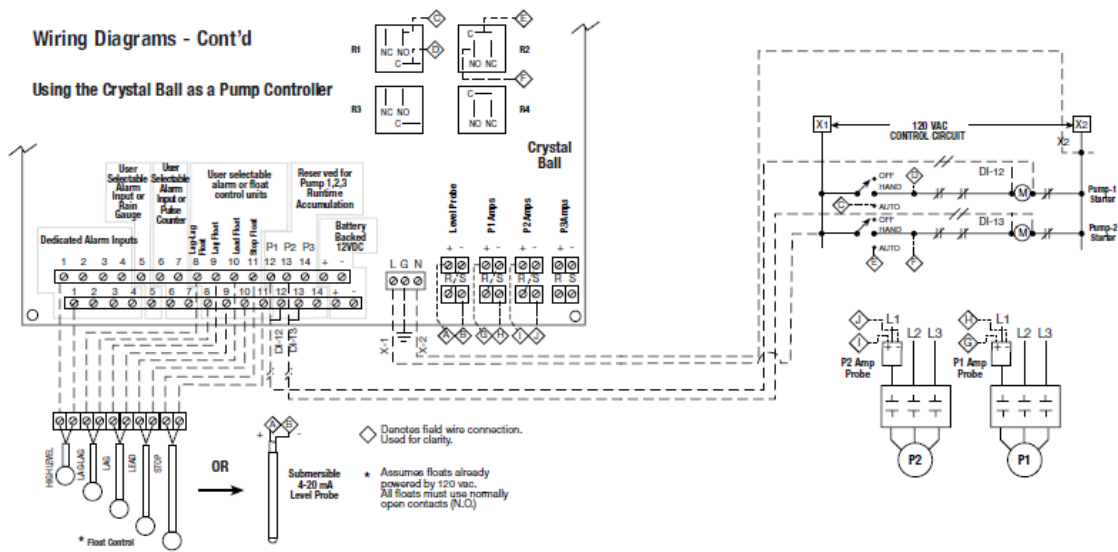

Figure-1 shows where to land all your wires on a Crystal Ball for both float-only control and 4-20mA control. If you are doing float-only control, your floats must be connected to the digital inputs exactly as shown, and all your floats must have normally open contacts (yes, even your stop float)

Again referring to Figure-1, if you are doing 4-20mA transducer control, your level transmitter must be connected to analog input #1, and it must be wired as shown. Our general solution is general purpose and IS NOT class I, div 1,2 rated.

Lastly, you will wire the Crystal Ball relays to pumps 1,2,3 exactly as shown. If you don't have (3) pumps then only wire the floats and relays based on how many pumps you have. In the display configuration step, you will select the number of pumps in the system, so your Crystal Ball controls the correct number of pumps.

# Crystal Ball Kit

## Comprehensive User Guide

Wiring Diagrams - Cont'd

Monitoring a Typical Pump Control Panel

Fig. 2

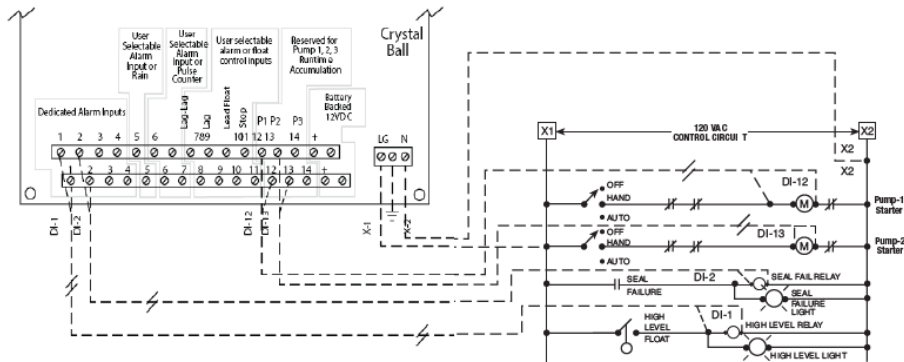

Next, referring to Figure-2, you must connect your pump run contacts inputs to Crystal Ball digital inputs 12,13, 14, respectively, for pumps 1,2,3. These inputs must be wired or the Crystal Ball cannot accumulate pump runtime and cycles, and also it would not be able to detect that a relay called for a pump to start, and it did not start.

If you have any additional alarms you wish to wire, they can be connected to the spare available digital inputs as shown in Figure-2

### Quickstart Guide for Using the Crystal Ball as Your Primary Pump Controller

- The Crystal Ball can be mounted outside of your pump control panel using the optional OmniSite NEMA 4x enclosure.
- Alternately, the Crystal Ball can be mounted inside of a new pump control panel (as room allows), and the removable display of the Crystal Ball can be mounted on the face of your inner swing-out door as follows:

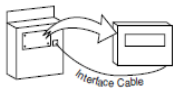

Note: Display is not waterproof and should not be mounted directly outdoors

- The Crystal Ball has (3) options for pump control:
  - Float-only control
  - 4-20 mA Analog level control
  - 4-20 mA w/ float backup control
- If using "float only" control, then wire as shown in diagrams on pages 15,16 of this manual. Note: the diagram in this manual on P15 assumes your floats are powered by an external 120 VAC source. If not, and the Crystal Ball will be supplying the power to floats, then wire your floats as show on page 10 of this manual titled "Example - Monitoring Dry, Unpowered Contacts"

If using float-only control they should be wired as follows:

Pump-3	LAG-LAG Float	Input 8
Pump-2	LAG Float	Input 9
Pump-1	Lead Float	Input 10
All Stop	Stop Float	Input 11

- If using analog-only control, then connect your 4-20 mA device to Analog input #1 (only) according to the diagrams on pages 11 & 12 of this manual.
- If using Analog plus float backup control then wire your analog device as detailed in step 5 above, then wire your high level float to input #1, and your stop float to input #11. The analog float backup uses only (2) floats and works as follows:
  - If your analog signal drops below 3 mA or above 22 mA, it is assumed the signal has "failed".
  - If the analog has failed, and the high float is energized, then the lead pump is started. If 15 seconds elapses and the high float is still energized, then the lag pump is started. If 15 additional seconds elapses, with both pumps running, and high float is still energized then the final pump is started.
  - All pumps will run (i.e. however many were started) until the stop float is de-energized.
  - This process will repeat until the analog signal is repaired.

- Relay Outputs - Note that the Crystal Ball relay outputs are "pre-assigned" as follows:
  - Relay-1 Pump-1
  - Relay-2 Pump-2
  - Relay-3 Pump-3
  - Relay-4 Spare-for custom use

- Once your wiring connections are made, you HAVE TO enter the following setup parameters using the Crystal Ball local keypad:
  - Number of Pumps being controlled
  - Your pump start/stop setpoints (if using analog sensor)
  - Type of tank level measuring device you are using (i.e. floats, or analog, or analog w/ float backup)
  - Pump GPM rating
  - Tank Dimensions

Refer to Appendix A for Crystal Ball Menu Tree and how to navigate to the settings above.

- When finished, test your setup using the Crystal Ball dedicated "Level Test" button. This button only works if you are using analog-only or analog with float backup control. If you are using Floats-only, then the best way to test your setup is just manually "tip-up" each float as needed.
- Note that if you are measuring pump amps with the Crystal Ball, then the amp probes must be connected as follows:

Analog-2	Pump-1 amp probe
Analog-3	Pump-2 amp probe
Analog-4	Pump-3 amp probe

Review the above summary, and the below image of a lift station wet well to determine that all your wires are connected properly, and that your floats and 4-20mA level transducer are suspended at the correct elevations

For float-only control, the lead float must be suspended in the well at an elevation higher than the stop float. Accordingly, the lag float must be higher than the lead float, the lag-lag float higher than the lag float, and the high-level float higher than all of them.

To ensure we understand the terminology, the lead float starts the first pump, the lag float starts the 2nd pump, and the lag-lag float starts the 3rd pump. They are called 1st, 2nd, and 3rd pumps because if you are using pump alternation (set in next section), the 1st, 2nd, and 3rd pumps will automatically change start positions to equalize pump runtime, so we don't call them pump 1, 2 and 3.

# Crystal Ball Kit

## Comprehensive User Guide

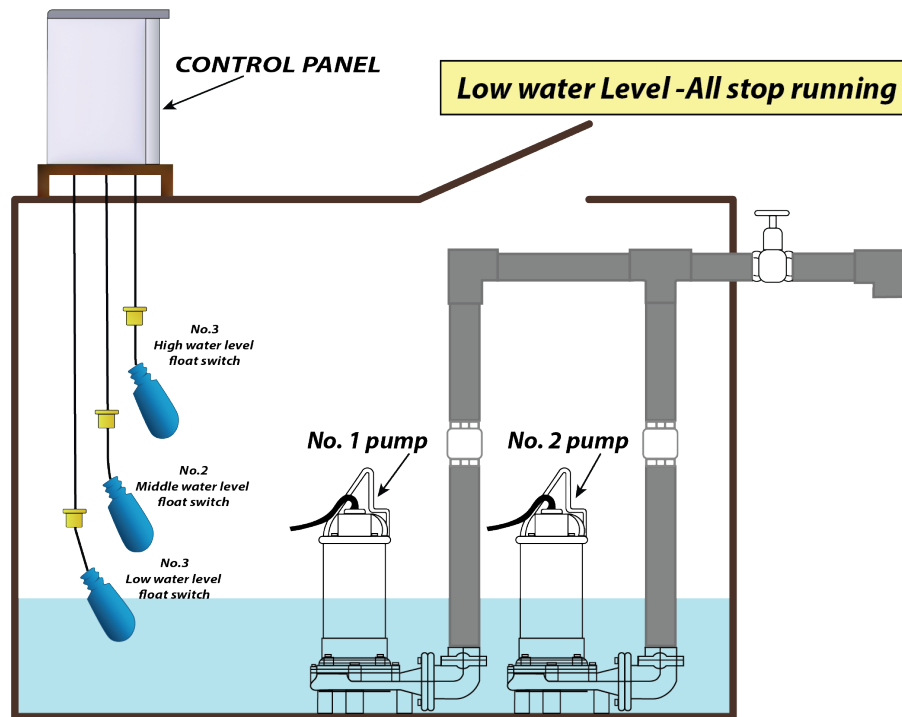

Now that your wires are connected to the correct terminals, and your floats and sensors are suspended at the correct levels in the well, you can proceed with configuring your pump control scheme and settings from the face of the Crystal Ball display/keypad assembly.



The above image shows how you can order the Crystal Ball with a detached display, and then mount the display on the front of an inner-swingout control panel. In this example, this inner-door is protected from outdoor weather by another outer weatherproof door. This way, an operator can access the Crystal Ball settings, without getting into the high voltage section of the control panel where the Crystal Ball controller is mounted.

# Crystal Ball Kit

## Comprehensive User Guide

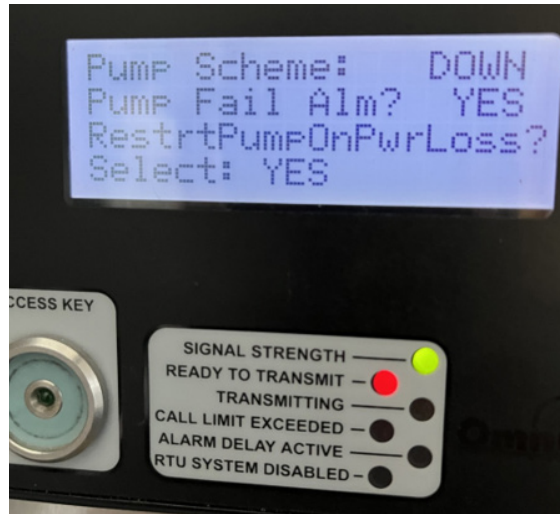

You'll start programming your pump control by first pushing the button on the face of the Crystal Ball named "Pump Settings" (note, you may need to press that key twice if the unit is in the screen saver mode). The above screen will appear. Next, we'll describe the purpose of each of the settings.

You can only adjust pump settings if the Crystal Ball is "disabled" with the SmartKey. Once disabled, you will note that the first setting is "blinking". This means the setting can be edited. To edit a setting, use the up/down arrow keys to move to your desired setting.

When that setting starts blinking, you can edit it by pressing the "enter" key. That allows you to enter the settings for that selected variable. You will adjust your variables using the

up/down keys. Remember to press "enter" when done making your setting change to save the entry. If you forget to press "enter" your setting will not be saved

Note that your settings are saved into flash memory in the Crystal Ball. This means the settings are permanent, and won't be lost even if your unit is powered down and without a back-up battery.

**Pump Scheme:** Your options are to select "pump up" or "pump down". When you select "pump up" this means when the Crystal Ball starts the pump(s), the pump(s) will be filling up a tank. Just like when a well pump is started to fill a water tower.

Selecting "pump down" means when the Crystal Ball starts the pump(s), they will be pumping down the water level. Like when a sewage pumping station is pumping down a well when the well level becomes too high. Select the correct setting for your application, and then press "enter" to save it. The menu will automatically move down to the next pump control setting

**Pump Fail Alarm:** Your options are "yes" and "no". Selecting yes means that when the Crystal calls for the pump to start, and if it does not actually start, then an alarm is issued to the Omnisite website, and you are notified of this event via email, text, or voice-call, IF AND ONLY IF the Omnisite Guard-Dog website is configured to call you on an alarm event. (See the Omnisite Quickstart Guide for how to configure callouts in the GuardDog website)

# Crystal Ball Kit

## Comprehensive User Guide

How does the Crystal Ball know that a pump didn't start? Referring to the above wiring diagrams, the run or auxiliary contacts from the pump motor starters must be wired into the Crystal Ball as shown. For a duplex pump system, run contacts from pump-1 would be wired into digital input 12, and pump-2 into digital input 13. If you had a 3rd pump, it would be wired into input 14. These run contacts must be normally open contacts. That means they are "open" when the pump is not running, and they close when the pump starts.

As an example for pump-1. When the Crystal Ball closes its relay-1 contacts to start pump-1, if the Crystal Ball does not see that the contacts connected to digital input 12 close after a few seconds, it issues you an alarm. This same sequence applies for pumps 2 and 3.

**Restart Pump on Power Loss:** your options are "yes" and "no". You'll likely always want to select "yes". When "yes" is selected, your pump will automatically restart after a system power failure. If you select "no" it won't until you go to the front of the Crystal Ball and "clear" the event. Some factory operations, for safety reasons, they choose to not auto-restart pumps and motors after a power failure event, however, most remote equipment does auto-restart after a power failure to prevent adverse "flood" consequences

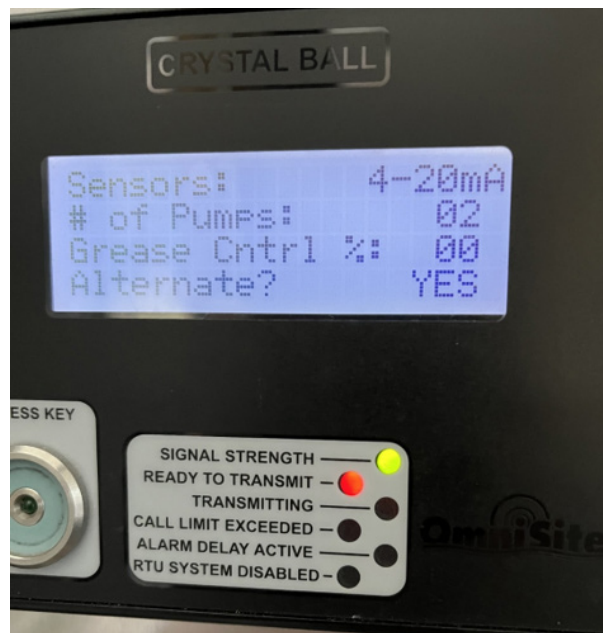

**Sensors:** Using the "down" arrow key on your keypad, will bring you to the "sensors" menu item. You have (3) options here. You can control your pumps with a 4-20mA transmitter, only. You can control your pumps with floats only. Or you can control your pumps with a 4-20mA transmitter and back-up floats. Why would you use different schemes? We'll explain here. There is no right or best answer. It typically comes down to engineer or operator preference, although Omnisite will make OUR RECOMMENDATION to you as well.

**4-20mA** – This selection means you connected a 4-20mA level transmitter into analog input-1 on the Crystal Ball. It must be connected to input-1 for pump control. It will not control your pumps connected to any other analog inputs. It can be any brand or type of 4-20mA transmitter. Omnisite sells submersible and radar level transmitters, and there are many, many others on the market. If you select this option, the Crystal Ball monitors only the 4-20mA reading on analog-1 to control your pumps on/off.

# Crystal Ball Kit

## Comprehensive User Guide

**Floats** – if you prefer to use floats to control your pumps, they must be wired as shown in the above diagram. All your floats MUST BE NORMALLY OPEN FLOATS, and they must be connected to the inputs exactly in the sequence shown. Once your floats are connected as shown, you would select “floats” to use those floats to control your pumps

**4-20mA+Floats-** With this scheme, the Crystal Ball will monitor the 4-20mA signal on analog-1, and also uses two back-up floats. Your “high” or start float must be wired to digital input-1, and your “low” or stop float wired into digital input #11. These floats must have normally open contacts. You must place your 4-20mA transmitter and floats into the tank as shown so that the analog level plus float control is sequenced correctly. To be sequenced correctly, the start/stop backup floats must be positioned “outside” of the normal operating range of the 4-20mA sensor on/off setpoints. If the water level would tip-up a high level float (indicating a failed 4-20mA transducer, or a pump that just can’t keep up with inflow, then the start float will override the 4-20mA signal to start pumps 1,2,3 as needed. All pumps will run together until the well level is lowered to the stop float, and then all pumps stop

**None-** use this setting is you aren’t using the Crystal Ball for pump control

**# of Pumps:** Select the number of pumps in your system, 1,2, or 3

**Grease Control %:** Use this setting to randomize your on/off setpoints when using a 4-20mA transmitter to extend how long it takes to build up grease rings in your well. Adjustable from 0-10%. It works as follows. For example, say that you are using the Omnisite transmitter that is always scaled for 0-20ft of water. If you selected 3%, then 3% of 20ft is 0.6 feet, or 7.2 inches. That means the Crystal Ball would randomize the on/off level of each setpoint anywhere between 0 to 7.2 inches on successive starts. Be careful, as this feature can really “fake people out”. They forget that this setting is turned on, and don’t understand why the pumps are starting at different levels!

**Alternate:** if you want your pumps to alternate on successive starts to equalize pump runtime (we recommend this) then select yes, and if not, and you want them to start in the identical sequence every time, select “no”.

**Omnisite’s recommendations?** – if you are using the Crystal Ball as your primary pump controller, use the 4-20mA+(2) float backup option. If you are using the Crystal Ball as a back-up pump controller, save yourself some time, and just use the 4-20mA option. As a back-up controller, be sure to set your 4-20mA sensor on/off setpoints OUTSIDE of the normal operating range of your primary controller, or you will have two controllers with overlapping setpoints “fighting each other”!

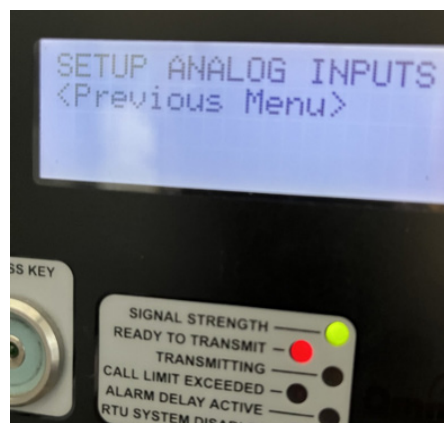

# Crystal Ball Kit

## Comprehensive User Guide

**Set Up Analog Inputs** – This section is covered in detail in the Crystal Ball Quick start guide, so your analog inputs should already be scaled correctly. If not, refer to that section in the QuickStart guide

This concludes the settings on the first pump control screen. Note, you will need to press the up/down arrow keys on the keypad to get to all these settings items as they don't all fit onto a single screen

Next, you'll select the button to the right of the "pump settings" button. It is labeled "Pump Bypass ". Press that button to go to your next steps



**P1 Runs-** Your options are "yes" or "no". "yes" means a pump-1 exists in the system, and you want it to be able to automatically start/stop. If pump-1 was out of service, you can set this to "no" and it will be removed from the pump alternation scheme to eliminate getting pump failure alarms. Also set to "no" if a pump does not exist

**P1 Control-** your options are "on", "off" and "auto". If you set this to "auto" the Crystal Ball will automatically start/stop the pumps according to the internal settings. You can use the "on" and "off" options to check your wiring. Set to on and the pump should start. Set to off and the pump should stop. Remember to set to auto before you leave

**P2 Runs-** Your options are "yes" or "no". "yes" means a pump-2 exists in the system, and you want it to be able to automatically start/stop. If pump-2 was out of service, you can set this to "no" and it will be removed from the pump alternation scheme to eliminate getting pump failure alarms. Also set to "no" if a pump does not exist

**P2 Control-** your options are "on", "off" and "auto". If you set this to "auto" the Crystal Ball will automatically start/stop the pumps according to the internal settings. You can use the "on" and "off" options to check your wiring. Set to on and the pump should start. Set to off and the pump should stop. Remember to set to auto before you leave

**P3 Runs-** Your options are "yes" or "no". "yes" means a pump-3 exists in the system, and you want it to be able to automatically start/stop. If pump-3 was out of service, you can set this to "no" and it will be removed from the pump alternation scheme to eliminate getting pump failure alarms. Also set to "no" if a pump does not exist

# Crystal Ball Kit

## Comprehensive User Guide

**P3 Control-** your options are “on”, “off” and “auto”. If you set this to “auto” the Crystal Ball will automatically start/stop the pumps according to the internal settings. You can use the “on” and “off” options to check your wiring. Set to on and the pump should start. Set to off and the pump should stop. Remember to set to auto before you leave

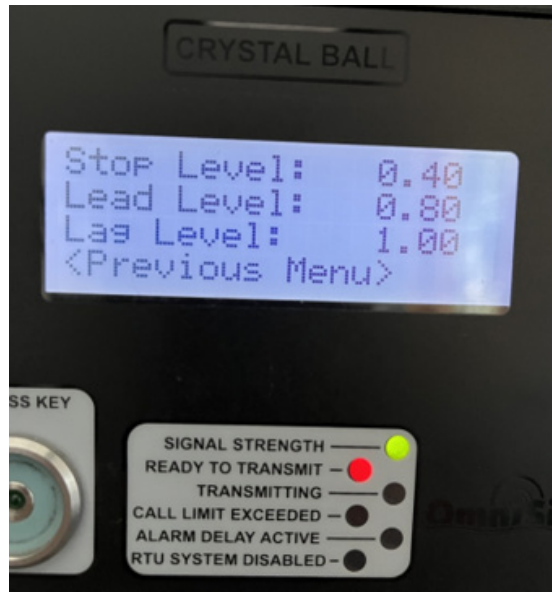

Now that you’ve selected which pumps will run in automatic control, if you are using 4-20mA control, you will now press the “Level Setup” button on the Crystal Ball display to set the elevations where your pumps will start/stop

**Stop Level-** This is the level in feet where all pumps start

**Lead Level-** this is the level in feet where the lead (1st) pump starts

**Lag Level-** this is the level in feet where the lag (2nd) pump starts

**Lag-Lag Level-** this is the level in feet where the lag-lag (3rd) pump starts

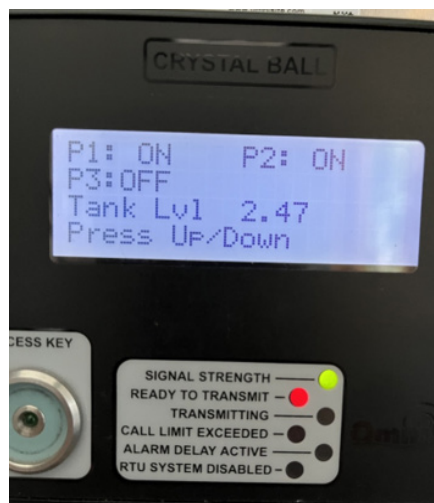

# Crystal Ball Kit

## Comprehensive User Guide

You're almost there! Now that everything is wired and configured in the Crystal Ball, the moment of truth has arrived. Make sure your pumps have power available, and all your pump hand-off-off switches are in the auto position. Select the "Level Test" button on the face of the Crystal Ball. Use the up/down keys to simulate the well level rising and falling (note – it's not actually rising and falling, this is a simulation)

Verify that all your pumps started and stopped at the level setpoints? If they didn't start, you'll need to carefully review your wiring and settings because something is in error. Making all these wiring connections and settings requires focus. Again, slowly and carefully review everything you've done. When done using level simulate be sure to exit this screen or your pumps will not operate in automatic mode!

### **Back-up Pump Control**

We have great news for you! To use the Crystal Ball as a back-up pump controller, you'll follow all the identical steps outlined above. The only thing to note is that your pump start/stop setpoints in the Crystal Ball **MUST BE SET OUTSIDE OF YOUR PRIMARY CONTROLLER ON/OFF SETPOINTS!**

---

# REFERENCE

---

# Crystal Ball Kit

## Comprehensive User Guide

**Little Known Fact about Solar Power:** If you are planning on using a solar array to power the Crystal Ball, this will obviously have an impact on your installation location. A solar array must have unobstructed sunlight during the day, which means it cannot be partially covered by a leaf shadow, or shadow of any kind. Solar arrays are wired in series, and if any part of it is in a shadow, then the entire array is dead (i.e. not putting out much, if any, power). Therefore, pick your solar panel location wisely, and face it to the south at a 45 degree angle. Also, if you are using solar power you will need to configure the Crystal Ball unit to use its low power mode. The default mode is for the cellular radio to remain powered on at all times when power is applied to the Crystal Ball to allow remote control from the web site. In low power mode, the radio is powered off after 1 minute of inactivity (see how to set low-power-mode in "Appendix A")

**STEP (1) Connect the OmniSite Crystal Ball to the equipment to be monitored using the wiring diagrams in this manual and turn it on.**

The monitor will automatically establish 2-way communications over the public cellular network to the [www.OmniSite.com](http://www.OmniSite.com) web site.

**STEP (2) Using the Local Display and Keypad**

We have good news for you. If you have physically connected your field wires according to the wiring diagrams in this manual, and you are using the Crystal Ball to merely monitor alarms, and provide pump runtime and on/off cycle information, then there are not any parameters that you have to set with the local display and keypad. The Crystal Ball default settings have been optimized for a typical sewage lift station at our factory, and it is going to work as such.

However, if you are using the Crystal Ball for automatic pump control on a sewage lift station measuring pump amps or using it in a drinking water system. THEN YOU MUST enter set point and control parameters as shown in APPENDIX A -LOCAL PROGRAMMING.

**STEP (3) Configuring Your Equipment on the OmniSite Website**  
Once your installation is complete, configuring your equipment on the OmniSite website is easy:

- This is a cellular device like a telephone and has an associated annual cellular service fee. **YOU MUST** contact OmniSite at 317-885-6330 with your billing information or this unit will not transmit alarms. We will activate the cellular service and provide the User ID and Password you will use to sign-on to your secure web pages.
- Sign-on to the OmniSite website at <https://guarddog.omnisite.com/login> using your newly selected User ID and Password.
- Once signed-on select "Setup" and then "Callout list" and also "Device Setup".
- Follow the steps on the screen to complete the alarm message delivery.
- OmniSite devices can automatically send emails, text messages and voice calls in any sequence in response to an alarm event. These features are configured using the website interface.
- Helpful hint - If you get stumped use the "Help" link that is at the top of each page. It has very specific information as to how to fill out the form you are currently working-on.
- **Don't like computers? No problem. OmniSite will set up your alarm for a small fee. Simply call us at 317-885-6330. We will do the setup for you.**

Example - Monitoring Dry, Unpowered Contacts

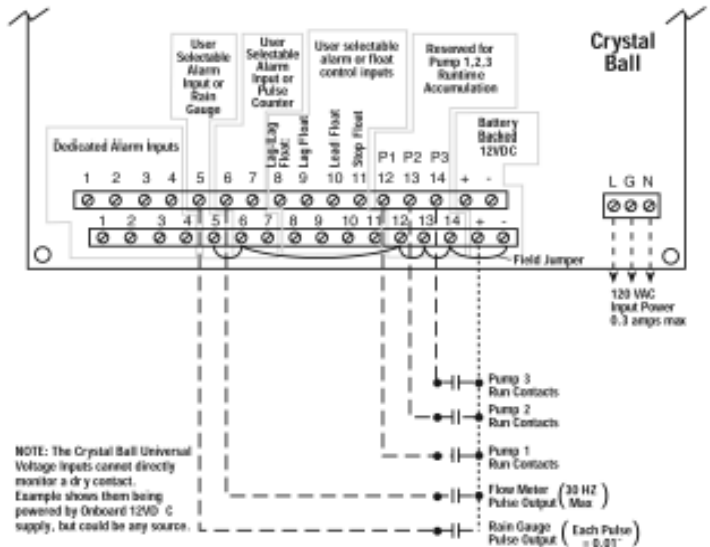

### Wiring Diagrams

The Crystal Ball Field Terminal Strip

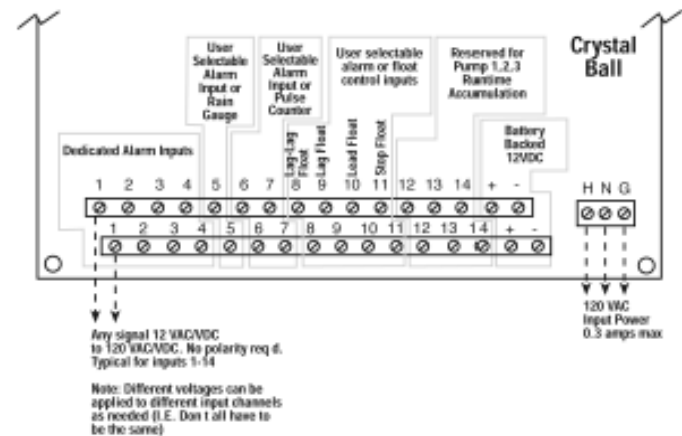

# Crystal Ball Kit

## Comprehensive User Guide

### Wiring Diagrams - Cont'd

#### Example Wiring 4-20mA Analog Inputs

\* Crystal Ball Analog Input  
Impedance = 250 ohms  
\*\* 12VDC @ 80mA max, each input

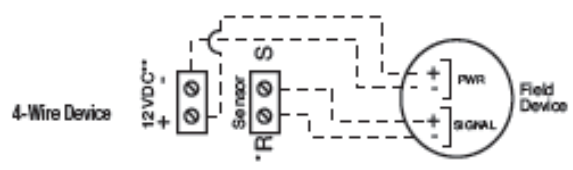
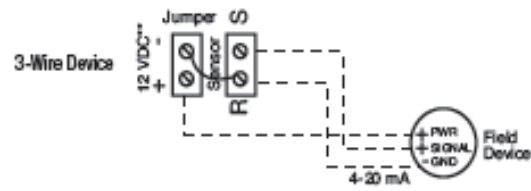
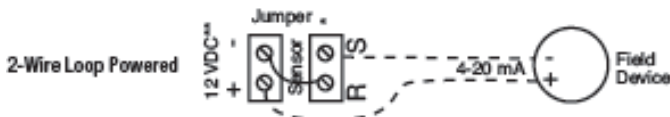

### Wiring Diagrams - Cont'd

#### Monitoring a Typical Pump Control Panel

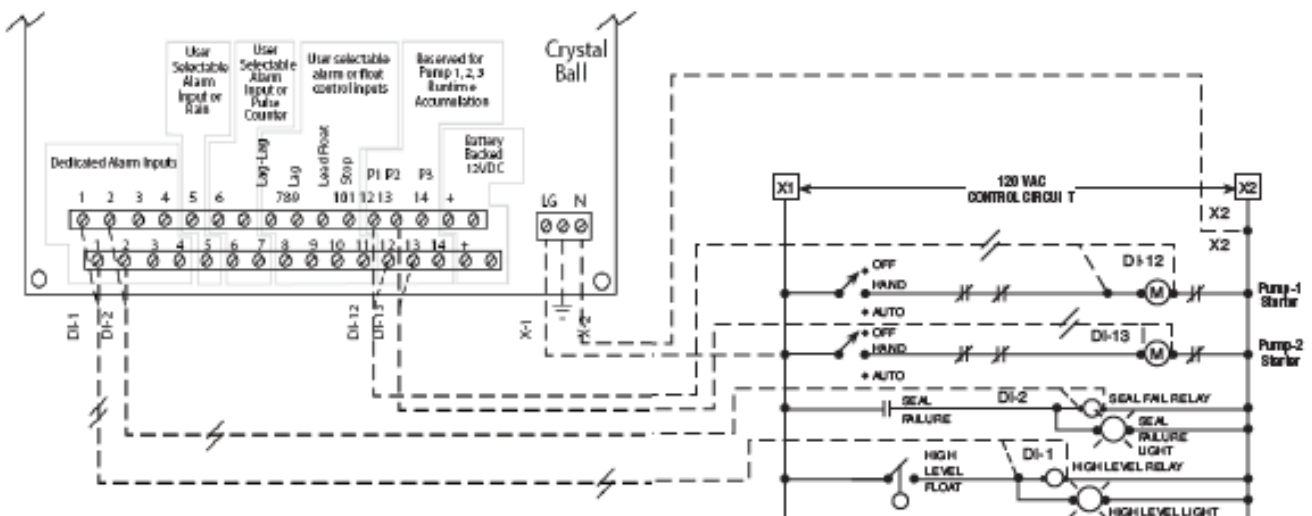

# Crystal Ball Kit

## Comprehensive User Guide

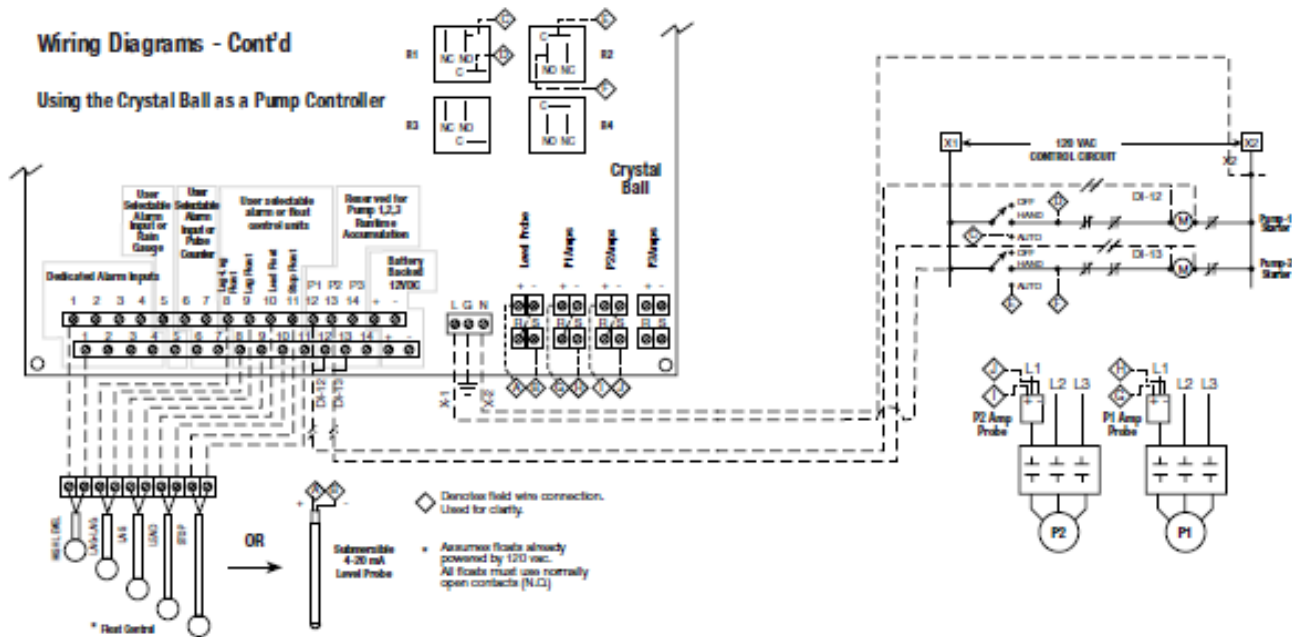

### Quickstart Guide for Using the Crystal Ball as Your Primary Pump Controller

- The Crystal Ball can be mounted outside of your pump control panel using the optional OmniSite NEMA 4x enclosure.
- Alternately, the Crystal Ball can be mounted inside of a new pump control panel (as room allows), and the removable display of the Crystal Ball can be mounted on the face of your inner swing-out door as follows:



Note: Display is not waterproof and should not be mounted directly outdoors

- The Crystal Ball has (3) options for pump control:
  - Float-only control
  - 4-20 mA Analog level control
  - 4-20 mA w/ float backup control
- If using "float only" control, then wire as shown in diagrams, on pages 15,16 of this manual. Note the diagram in this manual on P15 assumes your floats are powered by an external 120 VAC source. If not, and the Crystal Ball will be supplying the power to floats, then wire your floats as show on page 10 of this manual titled "Example - Monitoring Dry, Unpowered Contacts"

If using float-only control they should be wired as follows:

Pump-3	LAG-LAG Float	Input 8
Pump-2	LAG Float	Input 9
Pump-1	Lead Float	Input 10
All Stop	Stop Float	Input 11

- If using an analog-only control, then connect your 4-20 mA device to Analog input #1 (only!) according to the diagrams on pages 11 & 12 of this manual.
- If using Analog plus float backup control then wire your analog device as detailed in step 5 above, then wire your high level float to input #1, and your stop float to input #11. The analog float backup uses only (2) floats and works as follows:
  - If your analog signal drops below 3 mA or above 22 mA, it is assumed the signal has "failed".
  - If the analog has failed, and the high float is energized, then the lead pump is started. If 15 seconds elapses and the high float is still energized, then the lag pump is started. If 15 additional seconds elapses, with both pumps running, and high float is still energized then the final pump is started.
  - All pumps will run (i.e. however many were started) until the stop float is de-energized.
  - This process will repeat until the analog signal is repaired.
- Relay Outputs - Note that the Crystal Ball relay outputs are "pre-assigned" as follows:
  - Relay-1 Pump-1
  - Relay-2 Pump-2

# Crystal Ball Kit

## Comprehensive User Guide

- Relay-3 Pump-3
- Relay-4 Spare-for custom use

8. Once your wiring connections are made, you **HAVE TO** enter the following setup parameters using the Crystal Ball local keypad:

- Number of Pumps being controlled
- Your pump start/stop setpoints (if using analog sensor)
- Type of tank level measuring device you are using (i.e. floats, or analog, or analog w/ float backup)
- Pump GPM rating
- Tank Dimensions

Refer to Appendix A for Crystal Ball Menu Tree and how to navigate to the settings above.

9. When finished, test your setup using the Crystal Ball dedicated "Level Test" button. This button only works if you are using analog-only or analog with float backup control. If you are using Floats-only, then the best way to test your setup is just manually "tip-up" each float as needed.

10. Note that if you are measuring pump amps with the Crystal Ball, then the amp probes must be connected as follows:

- Analog-2 Pump-1 amp probe
- Analog-3 Pump-2 amp probe
- Analog-4 Pump-3 amp probe

(Inputs 8 thru 11)

Alternatively, these inputs can monitor and totalize pulses from a pulse output device at a max. rate of 30Hz (used to read flow and electric meters)

Connection of any "ON/OFF" style voltage signal in the range or 12VDC or 12VAC thru 120VAC or circuits to monitor alarms (pilot lights, relays, coils, etc.) No polarity has to be observed on these inputs and different inputs can have different voltage/polarities. All alarms have user adjustable alarm time delays thru the local display/keypad.

Alternatively, these inputs can be user selectable to monitor float switches and provide pump control using the relay outputs on the controller. If float control is desired – must be configured as shown in APPENDIX A – local programming.

(Inputs 12 thru 14)

These inputs are reserved to monitor the coil or auxiliary contacts from Pump-1,2, and 3 motor starters. Connection of any "ON/OFF style" voltage signal in the range of 12VDC or 12VAC thru 120VAC or 120VDC can be connected directly to these input circuits to monitor the pump run status. No polarity has to be observed on these inputs. These inputs provide daily reports of Pump-1,2,3 on/off cycles, total runtime, and GPM using timed draw downs on the well, as well as total station flow without the need for a flow meter. (Note: Flow calculations DO NOT work on stations using variable speed drives, and note that inputs 12,13,14 must be used with

normally open contacts to correctly accumulate runtime (e.g. voltage is applied to input 12,13, or 14 when the respective pump is running)

Analog inputs 1-4

Connection of any 4-20mA device signal allows remote monitoring and alarm set point notification.

Relay outputs 1-4

Connect to automatic control circuit of pump motor starter to provide automatic pump-up (drinking water applications) or pump-down (sewage lift stations).

(+ and - Term)

These terminals supply a continuous, battery backed 12VDC to any dry un-powered contacts providing alarm monitoring in the absence of AC power.

### Crystal Ball Field Input/Output Circuit Functionality

INPUT	DESCRIPTION	
(Inputs 1 thru 4)	Connection of any "ON/OFF style" voltage signal in the range of 12VDC or 12VAC thru 120VAC or 120VDC can be connected directly to these input circuits to monitor alarm signals (pilot lights, relays, coils, etc). No polarity has to be observed on these inputs, and different inputs can have different polarities/voltages. All alarm inputs have user adjustable alarm time delays adjustable thru the local display/keypad.	Analog inputs 1-4
(Input 5)	Connection of any "ON/OFF style" voltage signal in the range of 12VDC or 12VAC thru 120VAC or 120VDC can be connected directly to this input circuit to monitor alarms (pilot lights, relays, coils, etc). No polarity has to be observed on this input. All alarm inputs have user adjustable alarm time delays adjustable thru the local display/keypad. Alternatively, this input can monitor and totalize pulses from a rain gauge (used to plot rainfall vs. well inflow rate)	Relay outputs 1-4
(Inputs 6 and 7)	Connection of any "ON/OFF style" voltage signal in the range of 12VDC or 12VAC thru 120VAC or 120VDC can be connected directly to these input circuits to monitor alarms (pilot lights, relays, coils, etc). No polarity has to be observed on these inputs. All alarm inputs have user adjustable alarm time delays adjustable thru the local display/keypad.	(+ and - Term)

# Crystal Ball Kit

## Comprehensive User Guide

### Appendix A - Local Programming

Easily navigate the Crystal Ball display as follows:

- 8-button interface
- Display is Liquid Crystal Display 4 x 20
- While working through menu structure:
  - Pressing UP or DOWN will select the next or previous menu item in the list. To select that item, press ENTER. If the item is a menu selection, the next menu will open. If the item is a value, then it is selectable to edit.
  - Pressing EXIT for 2 seconds will return the user to the main menu.
  - Pressing EXIT momentarily will return the user to the previous menu.
- While editing a value:
  - If the value is numeric, the cursor will blink on the digit being edited.
  - If the value is a list, the list selection will blink. UP and DWN will be used to scroll through the list or make edits.
  - EXIT will cancel any editing WITHOUT saving the changes.
  - ENTER will move the cursor to the next position. If currently editing the last position or a list value, the value is SAVED and the user returns to the menu mode.
- Use of Dedicated Function Keys
  - Pressing "Level Setup" brings the user directly to the pump on/off setpoints for editing or review when using pump control.

- Pressing "Level Test" brings the user directly to the simulation screen that allows the user to use the UP/DOWN keys to simulate a rising and/or falling liquid level. This is used to test pump start/stop set points and alarm limits.
- "Pump Bypass" is used to take a pump out of automatic alternation if it is shut off for service or repair. Taking it out of rotation also prevents false alarms from occurring each time the Crystal Ball attempts to start the failed pump, and it fails to run. Through this menu option it is also possible to manually turn an output on or off.

Holding EXIT for 2 seconds can be pressed at any time to return to the main menu.

**NOTE:** The Crystal Ball RTU must be disabled with the Intelligent ID key before setup changes can be made. When finished with setup, again use your Intelligent ID key to put the Crystal Ball RTU back into service.

#### Crystal Ball Menu Tree

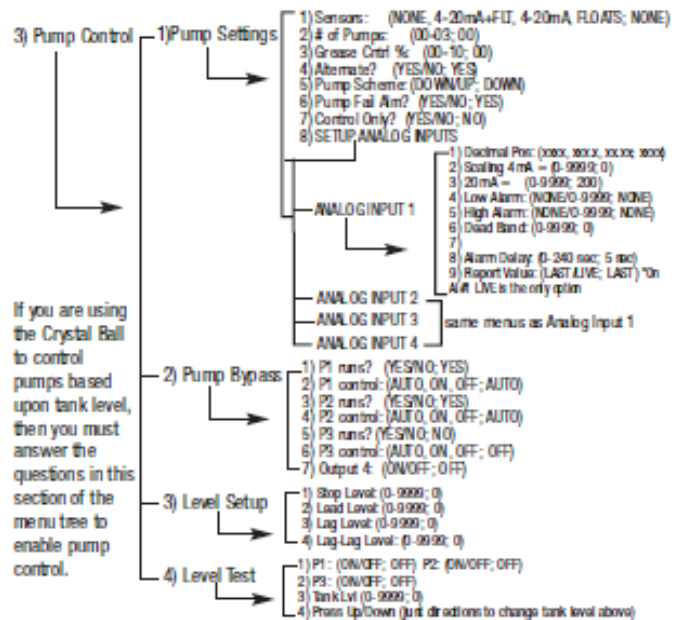
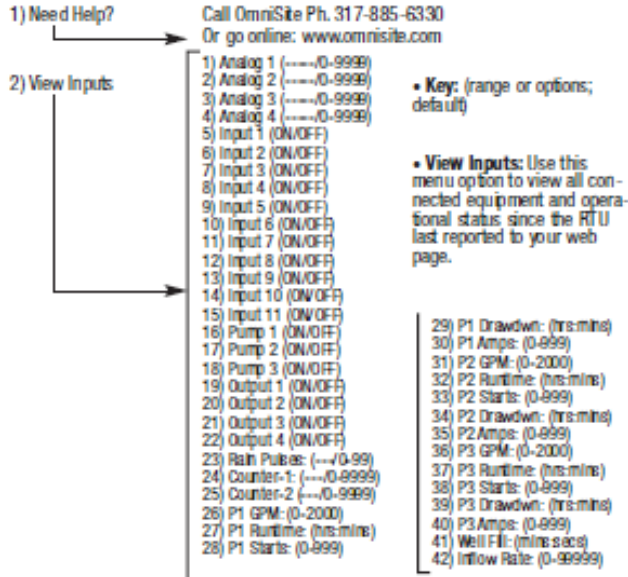

# Crystal Ball Kit

## Comprehensive User Guide

### Crystal Ball Menu Tree

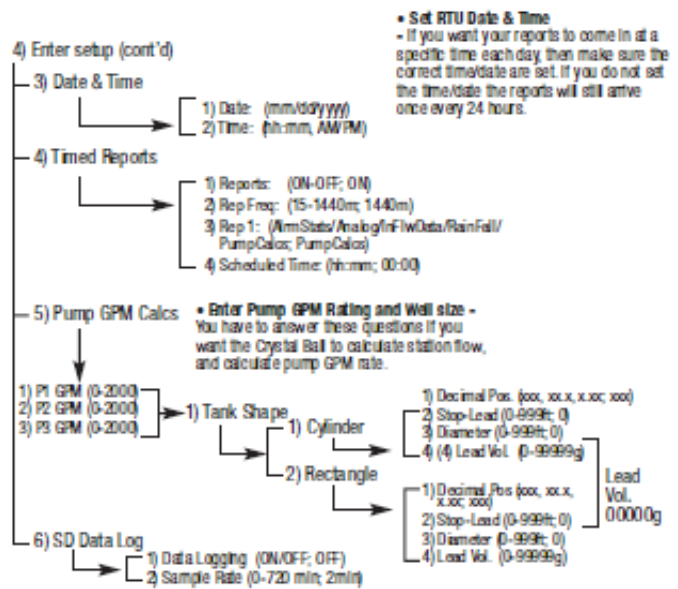
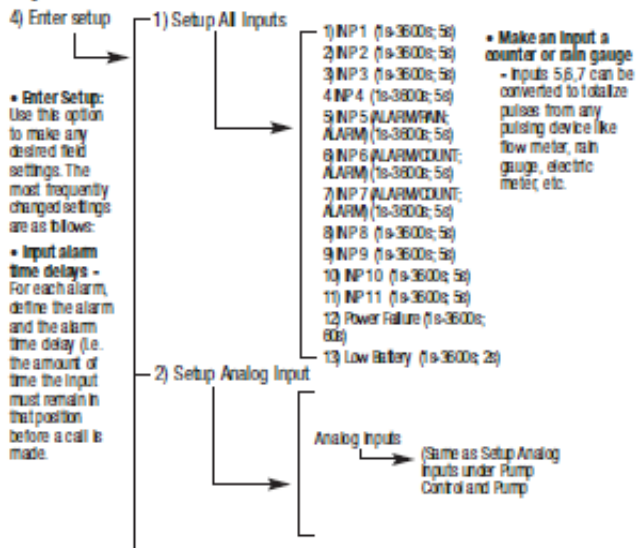

### Crystal Ball Menu Tree

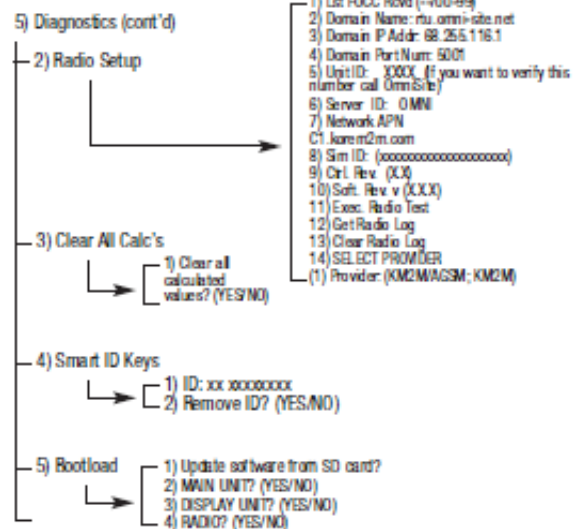
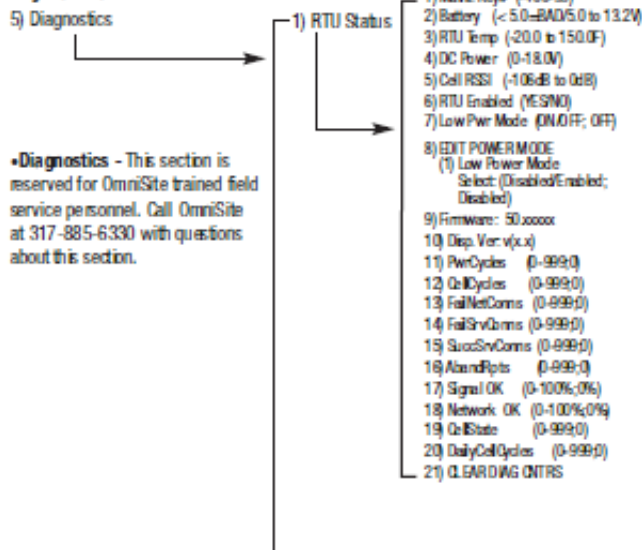

# Crystal Ball Kit

## Comprehensive User Guide

### Appendix E - Location for Setting Software Parameters

Process	Unit	Website
Enter input time delays	√	
Enter wet well dimensions	√	
Enter datalogging parameters	√	
Enter pump controller settings	√	
Enter analog high/low set points	√	
Enter analog measuring range	√	√
View current pump calculations & counter readings	√	√
View current analog/digital input status	√	√
Setup GPM override		√
Setup recipient email, phone and text information		√
Setup call-out list order and delays		√
Setup alarm state for inputs		√
Setup notification events		√
View charts, graphs and export data		√
View logs and history		√
Analyze inflow and rainfall		√



Place the maintenance key up to the "access Key" to ENABLE/DISABLE the unit

You can use the maintenance key to enable/disable the unit to eliminate false alarms while working on pumps, as well as time/date stamp when someone arrives onsite/leaves the site, to fix an alarm situation

---

# **FREEBIES**

---

# **F**REEBIE ZONE

## Snag Your Perks!

From custom merch to surprise goodies we're always dropping new freebies just for you.

Wanna see what's up for grabs right now?

Scan the QR code below to see the full list of what's available this month!

## Featured Freebies

- Tote bags
- T-shirts
- Safety Glasses
- Travel mugs
- GuardDog Stress Toy
- ...and more surprises

## How To Claim

1. Scan the QR Code
2. Chose the Freebie of your choice
3. Submit Form

**SCAN HERE**  
TO SEE WHAT'S  
AVAILABLE!





# Are OmniSite Products Right for You?

Our cloud-based software removes the need to buy, install, manage, and maintain custom software. Instead, you simply login to our GuardDog platform that is available 24/7 via our web or mobile app. We utilize reliable cellular technology to deliver your important alerts, so there is no need to run dedicated phone wires to your equipment. In summary, we offer cost-effective and reliable solutions to your water monitoring needs.

Instead of being all things to all people, at OmniSite we decided it was most important to focus our energy on becoming leading experts in what we do - monitoring water/wastewater. If you have a unique need or process that our products don't meet, we are happy to provide you with recommendations using our knowledge of alarm monitoring.



## COST-CUTTING EQUIPMENT

OmniSite monitoring equipment gives you the overall best value for your cellular alarm monitoring needs. Our cloud-based software allows you to track all your pump stations online or on the mobile app without the investment in additional infrastructure like servers or dedicated IT experts. We take care of that for you. Unlike SCADA systems and other expensive equipment, OmniSite products are a solution to your exact application without the costly price tag. We pride ourselves in helping our customers cut costs without sacrificing reliability and other features they value.



## ANYWHERE ACCESS

Because OmniSite products work off of the cellular network, you can receive important alerts anywhere via call, email, or text. OmniSite devices do what you can't - they monitor 24 hours a day, 7 days a week. With a web interface and mobile app called GuardDog, OmniSite can be compared to most SCADA systems as we are equipped to offer data logging, reporting, remote commands, immediate alerts upon detection, and more. With settings that allow you to receive status reports as frequently as every 15 minutes and alarms instantly, you can relax knowing you will always be informed. Need an instant update on if a station is functioning normally? OmniSite products make it easy with a simple command option that will send you a real-time update.



## RESPECTED & RELIABLE

OmniSite is consistently regarded as a leader in our industry. We are a small, family-owned company that understands the importance of treating all of our customers as if they are our only customer. Our products can have a big impact on the environmental health, so we are dedicated to being the most reliable solution with the best customer support available. OmniSite has been in business for over 20 years thanks to our loyal customers.





## EASY INSTALL, EASY USE

OmniSite products are more user-friendly and easier to install than alternative options. Not every application needs an expensive and complex SCADA system. Our products are simple but offer features that are important to you like access to reporting through GuardDog, our web and mobile app-based platform.



# OmniSite Product Comparison Chart

Whether you're looking for a low-cost solution to meet compliance guidelines, or need a monitoring device with built-in pump control options, OmniSite has a product for all your pump station needs.

	 <b>OmniBeacon</b>	 <b>XR50</b>	 <b>Crystal Ball</b>
Digital Inputs	2	10	14
Analog Inputs	NO	NO	4
Relay Outputs	NO	NO	4
Backup Battery	YES	YES	YES
LCD Display	NO	2 Line X 16 Characters	4 Line X 20 Characters
Can Be Purchased with a NEMA 4X enclosure	N/A	YES	YES
Can Be Mounted Directly in the Panel	Mounts on Top or Side of Panel	YES	YES
Sends Real-Time Alerts via Text, Email, or Call	YES	YES	YES
Eligible for Elite Reporting	NO	YES	YES
Provides Access to Pump Data (GPM, Runtimes, On/Off Cycles, Rainfall, Pump Failure, etc.) via GuardDog	NO	YES	YES
Eligible for OmniAdvantage Plan	YES	YES	YES

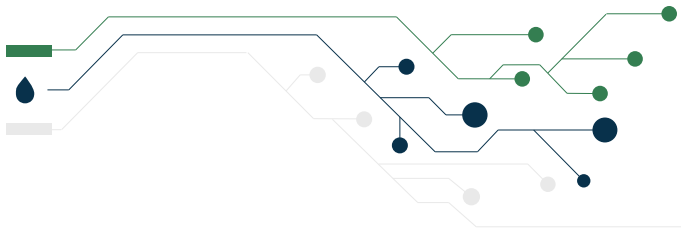

# Do You Really Need a SCADA System?

Depending on the size of your treatment plant, municipal budget, and individual needs, a SCADA system might be in fact overkill. OmniSite offers an affordable alternative with real-time alerts, daily data reporting with the option to upgrade to every 15 minutes, and simple, easy-to-use units that communicate with you through reliable cellular networks. So the question remains: do you really need a SCADA system? Still on the fence? Below is a breakdown of how OmniSite compares to SCADA.



## SCADA IS EXPENSIVE

**SCADA** systems have high fees associated with installation and maintenance. Add in bidding for companies to install it, annual data fees, and cost of massive, expensive hardware, and your price tag has increased exponentially.

**OmniSite** uses tiny data packets through cellular networks to deliver you data quickly and affordably. Plus our annual cost for cellular service has not increased in over a decade.

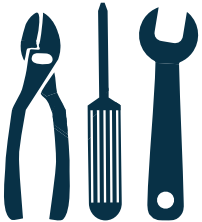

## SCADA IS HIGH MAINTENANCE

**SCADA** systems have many interconnected parts and pieces. If something breaks it can be difficult to locate the faulty part. This puts your treatment plant at risk and behind schedule until the problem can be located and fixed.

**OmniSite** units are simple by design. Plus, with our new OmniAdvantage Plan subscription, if something breaks, send it in and we'll test it and fix it for you.

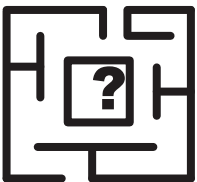

## SCADA IS COMPLICATED

**SCADA** is a massive, complicated system designed for the likes of major cities such as Chicago and New York. It's unrealistic to force your municipality to pay for and utilize the exact same complex system for a much smaller scale.

**OmniSite** is unit independent, meaning for however many pump stations you need monitored, that's how many units we provide. No more. No less. Only exactly what you need.

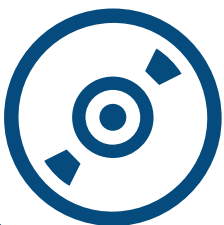

## SCADA HAS EXTERNAL SOFTWARE

**SCADA** is such a massive system that all the software required to fully utilize it doesn't come in one, easy to use package. This means software set up and updates from multiple, hard to track, sources.

**OmniSite's** state-of-the-art software comes FREE with every device purchase. Plus, our GuardDog mobile app allows you to have access to your data whenever, where ever.



# Do You Really Need a SCADA System?

## SCADA VS OMNISITE COST CALCULATOR

Due to the impactful cost of installing a SCADA system, it can be wise to examine the expense of other options by comparison. Below is a chart showing the 10 year installation and operating costs of 15 units on an SCADA system versus OmniSite units. You'll be surprised how much the savings add up. Want to see estimated cost of a different number of units? Try our online Cost Savings Calculator at [OmniSite.com](http://OmniSite.com)

SCADA 10 Year Cost on 15 Units	
Hardware Cost	\$5,000/station
Custom Panel Design/Build	\$2,800/station
Software Cost	\$800/station
Installation & Start up Cost	\$1,250/station
Cost for System Engineering	\$10,000
Procurement Cost main PC/Server	\$5,000
Cost of Programming MMI Software	\$2,500
Annual Budget for Server PLC Hardware, Software Upgrades, & Installation	\$12,500
Other charges, fees, bids, consultations, budgetary meeting expenses, etc	\$25,000
<b>Total First Year Cost on 15 Units</b>	<b>\$247,750</b>
9 Years of Cell/Telemetry Fee	\$185,400
<b>TEN YEAR TOTAL COST ON 15 UNITS</b>	<b>\$433,150</b>

OMNISITE 10 YEAR COST on 15 UNITS	
Material & Installation Labor	\$3,500/unit
Annual Cell/Telemetry Cost	\$290/unit
<b>Total First Year Cost on 15 Units</b>	<b>\$56,850</b>
9 Years of Cell/Telemetry Fee	\$39,150
<b>TEN YEAR TOTAL COST ON 15 UNITS</b>	<b>\$96,000</b>

TOTAL FIRST YEAR SAVINGS ON 15 UNITS  
**\$190,900**

TOTAL 10 YEAR SAVINGS ON 15 UNITS  
**\$337,150**



# OmniSite Training



OmniSite offers a comprehensive training course that covers the many aspects of installing OmniSite products, configuring alarms, and monitoring day-to-day activity. Training is hosted in our state-of-the-art Training Center, where we incorporate OmniSite devices into real-world control panels. The hands-on environment allows trainees to learn and work with real wastewater equipment so they are properly prepared to work with OmniSite devices in the field.

## About the Program

Our training program was designed with you in mind. Our hands-on labs, with a real pump station and quality instruction from OmniSite experts, will help you become a pro at using our products. The two-day course will allow new and familiar installers to gain valuable knowledge about the following subjects:

- Wiring of XR50, Crystal Ball, and OmniBeacon
- Step-by-step process of how to install an OmniSite unit
- Product activation
- Troubleshooting in the field
- GuardDog web- and mobile-interface training
- New product training



Attendees will engage in a tour of the OmniSite facility where students can see how our products are made and prepared for shipment. Additionally they'll receive lunch each day plus dinner the first evening.



## Take-Home Training Materials

Each attendee will receive a detailed, take-home training manual that contains product information, multiple step-by-step labs, control wiring overviews, troubleshooting information, and more.

Contact [sales@OmniSite.com](mailto:sales@OmniSite.com) to register today!



# OmniSite Training

## Training Where You Are With Free Webinars

OmniSite provides webinars covering topics to help both customers and sales representatives. These webinars are designed to give a better understanding of OmniSite products, tools and services.

Each webinar is held online with an OmniSite expert facilitating the session. Each individual attending has the ability to interact with the instructor to ask questions and voice concerns.

### Webinar Topics We Cover

- GuardDog Overview
- Activations and the Activation Wizard
- Product Overview
- Additional Topics by Request



## From Out of Town?

Our facility is located in downtown Indianapolis, just a short drive from the Indianapolis International Airport and within 10-20 minutes of several hotels.

Attendees are responsible for the following travel expenses:

- Airfare
- Car rental/gas
- Hotel
- Additional meals
- Entertainment

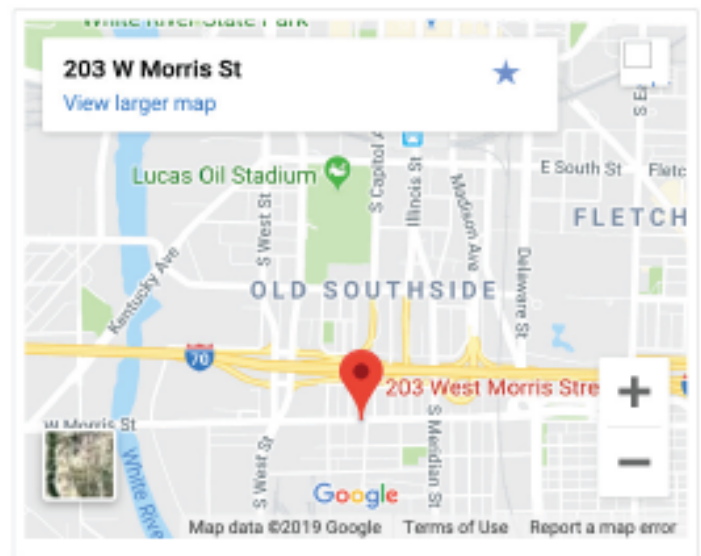

## Downtown Indy Hotel and Restaurant Recommendations

### Hotels

Staybridge Suites	\$	(317) 536-7500
Hampton Inn	\$\$	(317) 261-1200
HomeWood Suites	\$\$	(317) 636-7992

### Restaurants

Tavern on South	(317) 602-3115
lozzo's Garden of Italy	(317) 974 110
Slippery Noodle	(317)631-6974

# Crystal Ball Kit

## Comprehensive User Guide

### PRODUCT SAFETY, USE, AND LIMITED WARRANTY

---

The following safety and use information and Limited Warranty applies to products sold by OmniSite (“OmniSite”) to you the end-user (“You”) on OmniSite namely an alarm with text notification capability, related accessories such as sensors (collectively “Products”), and cellular service, which is required in order for the alarm to send notification text messages (“Services” collectively with Products “Products and Services”).

#### Product Safety and Use Information

**IMPORTANT:** Use only supplied battery and with your Products. Routinely check the battery in Products; failure to routinely check the battery may result in the failure of Products to function during a loss of power. Routinely check the strength of the cellular signal to Products and/or perform tests to check the text notification capability of the Products. **WARNING:** Products use electricity in the presence of water; therefore, your safety and the safety of others depend upon you thoroughly reading and understanding the Installation Guide. If you have questions or do not understand the information presented in the Installation Guide, please call 1-317-885-6330. Be sure that electrical cords used are not frayed or placed in a location where they can pose a danger. To reduce the risk of fire, electric shock, injury or death, always disconnect all sources of electrical power before servicing or cleaning; do not touch the electrical terminals or controls with wet hands; and do not tilt, jolt or tip Products while powered-on. Never disassemble Products. Never allow children to use Products.

#### Product Safety, Use & Limited Warranty

**CAUTION:** Products are cellular devices and must be activated before use. Please visit [OmniSite.com/activate](http://OmniSite.com/activate) to activate your Products. You must have a cellular device in which to communicate with Products. OmniSite utilizes automatic bill pay as a convenience to its customers and to ensure continuity of cellular service. OmniSite will notify you before cellular service is to be renewed and before the credit card you provided during activation is charged. If OmniSite is not able to successfully bill for the cellular service, OmniSite has the right to immediately disconnect cellular service to your Products and your Products will no longer send text notifications. **NOTE:** Upon delivery inspect contents immediately and file claim with delivery carrier for any damage. OmniSite recommends saving the original box and packing material. You are responsible for damage to Products if returned to OmniSite improperly packed. **NOTE:** OmniSite’s primary method for contacting you is via email. Please add us as a contact to ensure delivery of these emails. Please promptly update your email address with us if it changes.

**LIMITED WARRANTY:** OmniSite (“OmniSite”) warrants to You that Products will be free from defects in materials and workmanship under normal use and service for two (2) years from the purchase date. A claim under this Limited Warranty must be presented during the Limited Warranty period and within thirty (30) days after any covered condition has occurred. A claim under this Limited Warranty shall be satisfied by either, in OmniSite’s sole discretion, repairing or replacing the Products and/or part. Replacement Products may be new or reconditioned.

To make a claim under this Limited Warranty, OmniSite must first issue You a Returned Material Authorization (RMA) number. This number can be obtained by contacting OmniSite and a copy will be provided by email. A copy of the RMA must be included with any materials shipped to OmniSite. The entirety of Products must be sent back to OmniSite (unless specifically listed otherwise on the RMA form) and properly packaged to ensure against damage during shipping. If OmniSite determines that the claim is covered by this Limited Warranty, OmniSite will either, in its sole discretion, repair or replace the Products and/or part.

# Crystal Ball Kit

## Comprehensive User Guide

Any damages not covered under this Limited Warranty will not be repaired until a written purchase order is received. The Limited Warranty period shall not be extended by the replacement or repair of Products or parts under this Limited Warranty but the remaining Limited Warranty period shall continue in effect and be applicable to the replaced or repaired Products or parts under conditions of the Limited Warranty. Payment for cellular service covers only cellular transmission fees and in no way extends any portion of this Limited Warranty. This fee does not include out-of-warranty service or repair. The cellular service provided in conjunction with the purchase and use of Products and Services is not guaranteed, and OmniSite cannot and does not guarantee or represent that cellular service will be available in Your area nor that cellular service will be continuous and uninterrupted in Your area. It is Your responsibility to determine if cellular coverage is available in your area and to monitor the warning light on Products and Services to determine the cellular signal strength to Products and Services. You should contact OmniSite for assistance if needed. If cellular service is not available in your area, then your sole remedy is to return Products and Services as provided for in OmniSite's Return Policy as found at [www.OmniSite.com](http://www.OmniSite.com). As such, OmniSite is not liable for any causes of action, losses or damages of any kind whatsoever arising out of mistakes, omissions, interruptions, errors, or defects in the provision of cellular service and failures or defects in the cellular network. Upon expiration of the Limited Warranty period, all liability of OmniSite shall be terminated.

This Limited Warranty does not apply in the following cases: failure to follow installation and operating instructions, misuse, alteration, abuse, accident or tampering, and repair by anyone other than OmniSite. THIS LIMITED WARRANTY IS EXCLUSIVE AND EXPRESSLY IN LIEU OF ALL OTHER WARRANTIES, OBLIGATIONS OR LIABILITIES, WHETHER WRITTEN, ORAL, EXPRESS OR IMPLIED, INCLUDING ANY WARRANTY OF MERCHANTABILITY OR FITNESS FOR A PARTICULAR PURPOSE, OR OTHERWISE. IN NO CASE SHALL OMNISITE BE LIABLE TO ANYONE FOR ANY CONSEQUENTIAL OR INCIDENTAL DAMAGES FOR BREACH OF THIS WARRANTY OR ANY OTHER WARRANTIES WHATSOEVER. This Limited Warranty gives specific legal rights. You may have other rights, which vary from state to state. Some states do not allow the exclusion or limitation of incidental or consequential damages, so that the above limitation of exclusion may not apply to you. You, the individual user, should take care to determine prior to use whether Products and Services are suitable, adequate or safe for the use intended. Since individual applications are subject to great variation, OmniSite makes no representation or warranty as to suitability or fitness of Products and Services for any specific application.

OmniSite makes no representation that Products and Services will reduce any risk of property loss or personal injury or prolong the life of any equipment or other property; or that Products and Services will in all cases provide adequate warning and protection. You understand that Products and Services if properly installed and maintained may only reduce the risk of property loss or other loss but Products and Services, are not an insurance or a guarantee that there will be no property loss or other loss as a result. CONSEQUENTLY, OmniSite SHALL HAVE NO LIABILITY FOR ANY PROPERTY DAMAGE, PERSONAL INJURY OR OTHER LOSS BASED ON A CLAIM THE PRODUCTS AND SERVICES FAILED TO GIVE WARNING. However, if OmniSite is held liable, whether directly or indirectly, for any loss or damage arising under this Limited warranty or otherwise, OmniSite's liability shall be limited to the purchase price of Products and Services purchased and paid for by You, which shall be the complete and exclusive remedy against OmniSite.



# The OmniAdvantage Plan

## Put an end to repair and replacement costs.

- Lifetime Product Updates
- Lifetime Radio Upgrades
- Free Software Upgrades
- GuardDog Web Browser Setup and Priority Support
- Professional Training
- Free Spare If you have 5 or more units during the RMA process

## Want to learn more?

Contact one of our OmniAdvantage experts at *317-885-6330 ext: 137*  
Email [Sales@OmniSite.com](mailto:Sales@OmniSite.com)

## CONTACT US

---

### ADDRESS

---

203 W. Morris St.  
Indianapolis, IN 46225

### PHONE

---

Sales : 317-885-6330 x 4  
Support : 317-885-6330 x 3  
Main : 317-885-6330

### EMAIL / WEB

---

[sales@OmniSite.com](mailto:sales@OmniSite.com)  
[support@OmniSite.com](mailto:support@OmniSite.com)  
[www.OmniSite.com](http://www.OmniSite.com)